



**samlex**power®

**DC-AC Power  
Inverter**  
Pure Sine Wave

PST-3000-12  
PST-3000-24

Owner's  
Manual

Please read this  
manual BEFORE  
installing your  
inverter

# OWNER'S MANUAL | Index

<b>SECTION 1</b>	Safety Instructions .....	3
<b>SECTION 2</b>	General Information .....	7
<b>SECTION 3</b>	Limiting Electromagnetic Interference (EMI) .....	14
<b>SECTION 4</b>	Powering Direct / Embedded Switch Mode Power Supplies (SMPS) .....	15
<b>SECTION 5</b>	Principle of Operation .....	17
<b>SECTION 6</b>	Layout.....	18
<b>SECTION 7</b>	General Information on Lead-Acid Batteries .....	19
<b>SECTION 8</b>	Installation .....	30
<b>SECTION 9</b>	Operation .....	44
<b>SECTION 10</b>	Protections .....	47
<b>SECTION 11</b>	Troubleshooting Guide .....	51
<b>SECTION 12</b>	Specifications .....	53
<b>SECTION 13</b>	Warranty .....	55
 <b>APPENDIX A</b>		
<b>SECTION 8</b>	Installation (French)	

## Disclaimer of Liability

UNLESS SPECIFICALLY AGREED TO IN WRITING, SAMLEX AMERICA INC.:

1. MAKES NO WARRANTY AS TO THE ACCURACY, SUFFICIENCY OR SUITABILITY OF ANY TECHNICAL OR OTHER INFORMATION PROVIDED IN ITS MANUALS OR OTHER DOCUMENTATION.
2. ASSUMES NO RESPONSIBILITY OR LIABILITY FOR LOSSES, DAMAGES, COSTS OR EXPENSES, WHETHER SPECIAL, DIRECT, INDIRECT, CONSEQUENTIAL OR INCIDENTAL, WHICH MIGHT ARISE OUT OF THE USE OF SUCH INFORMATION. THE USE OF ANY SUCH INFORMATION WILL BE ENTIRELY AT THE USERS RISK.

Samlex America reserves the right to revise this document and to periodically make changes to the content hereof without obligation or organization of such revisions or changes.

## Copyright Notice/Notice of Copyright

Copyright © 2018 by Samlex America Inc. All rights reserved. Permission to copy, distribute and/or modify this document is prohibited without express written permission by Samlex America Inc.

# SECTION 1 | Safety Instructions

## 1.1 IMPORTANT SAFETY INSTRUCTIONS AND SYMBOLS

SAVE THESE INSTRUCTIONS. This manual contains important instructions for models PST-3000-12 and PST-3000-24 that shall be followed during installation, operation and maintenance.

The following safety symbols will be used in this manual to highlight safety and information:



**WARNING!**

Indicates possibility of physical harm to the user in case of non-compliance.



**MISE EN GARDE!**

L'utilisateur pourrait se blesser lorsque les consignes de sécurité ne sont pas suivies.



**CAUTION!**

Indicates possibility of damage to the equipment in case of non-compliance.



**ATTENTION!**

Il y a un risque d'endommager l'équipement lorsque l'utilisateur ne suit pas les instructions.



**INFO**

Indicates useful supplemental information.

Please read these instructions before installing or operating the unit to prevent personal injury or damage to the unit.

## 1.2 SAFETY INSTRUCTIONS - GENERAL

### Installation and wiring compliance

- Installation and wiring must comply with the Local and National Electrical Codes and must be done by a certified electrician.

### Preventing electrical shock

- Always connect the grounding connection on the unit to the appropriate grounding system.

## **SECTION 1 | Safety Instructions**

- Disassembly / repair should be carried out by qualified personnel only.
- Disconnect all AC and DC side connections before working on any circuits associated with the unit. Turning the ON/OFF switch on the unit to OFF position may not entirely remove dangerous voltages.
- Be careful when touching bare terminals of capacitors. Capacitors may retain high lethal voltages even after the power has been removed. Discharge the capacitors before working on the circuits.

### **Installation environment**

- The inverter should be installed indoor only in a well ventilated, cool, dry environment.
- Do not expose to moisture, rain, snow or liquids of any type.
- To reduce the risk of overheating and fire, do not obstruct the suction and discharge openings of the cooling fan.
- To ensure proper ventilation, do not install in a low clearance compartment.

### **Preventing fire and explosion hazards**

- Working with the unit may produce arcs or sparks. Thus, the unit should not be used in areas where there are flammable materials or gases requiring ignition protected equipment. These areas may include spaces containing gasoline-powered machinery, fuel tanks, and battery compartments.

### **Precautions when working with batteries**

- Batteries contain very corrosive diluted Sulphuric Acid as electrolyte. Precautions should be taken to prevent contact with skin, eyes or clothing.
- Batteries generate Hydrogen and Oxygen during charging resulting in evolution of explosive gas mixture. Care should be taken to ventilate the battery area and follow the battery manufacturer's recommendations.
- Never smoke or allow a spark or flame near the batteries.
- Use caution to reduce the risk of dropping a metal tool on the battery. It could spark or short circuit the battery or other electrical parts and could cause an explosion.
- Remove metal items like rings, bracelets and watches when working with batteries. The batteries can produce a short circuit current high enough to weld a ring or the like to metal and, thus, cause a severe burn.
- If you need to remove a battery, always remove the ground terminal from the battery first. Make sure that all the accessories are off so that you do not cause a spark.

## **1.3 SAFETY INSTRUCTIONS - INVERTER RELATED**

### **Preventing Paralleling of the AC Output**

The AC output of the unit should never be connected directly to an Electrical Breaker Panel / Load Centre which is also fed from the utility power / generator. Such a direct connection may result in parallel operation of the different power sources and AC power from the utility / generator will be fed back into the unit which will instantly damage

## SECTION 1 | Safety Instructions

the output section of the unit and may also pose a fire and safety hazard. If an Electrical Breaker Panel / Load Center is fed from this unit and this panel is also required to be fed from additional alternate AC sources, the AC power from all the AC sources (like the utility / generator / this inverter) should first be fed to an Automatic / Manual Selector Switch and the output of the Selector Switch should be connected to the Electrical Breaker Panel / Load Center. Samlex America, Inc. Automatic Transfer Switch Model No. STS-30 is recommended for this application.



### CAUTION!

To prevent possibility of paralleling and severe damage to the unit, never use a simple jumper cable with a male plug on both ends to connect the AC output of the unit to a handy wall receptacle in the home / RV.



### ATTENTION!

Des dommages causés par un inversement des polarités ne sont pas couverts par la garantie.

### Preventing DC Input Over Voltage

It is to be ensured that the DC input voltage of this unit does not exceed 16.5 VDC for the PST-3000-12 or 33.0 VDC for the PST-3000-24 to prevent permanent damage to the unit. Please observe the following precautions:

- Ensure that the maximum charging voltage of the external battery charger / alternator / solar charge controller does not exceed 16.5 VDC for the PST-3000-12 or 33.0 VDC for PST-3000-24
- Do not use unregulated solar panels to charge the battery connected to this unit. Under cold ambient temperatures, the output of the solar panel may reach > 22 VDC for 12V Battery System and > 44 VDC for the 24V Battery system. Always use a charge controller between the solar panel and the battery.
- Do not connect this unit to a battery system with a voltage higher than the rated battery input voltage of the unit (e.g. do not connect PST-3000-12 to 24V or 48V battery system or PST-3000-24 to the 48V Battery System)

### Preventing Reverse Polarity on the Input Side

When making battery connections on the input side, make sure that the polarity of battery connections is correct (Connect the Positive of the battery to the Positive terminal of the unit and the Negative of the battery to the Negative terminal of the unit). If the input is connected in reverse polarity, the external DC fuse and the DC fuses inside the inverter will blow and may also cause permanent damage to the inverter.



### CAUTION!

Damage caused by reverse polarity is not covered by warranty.

## SECTION 1 | Safety Instructions



### ATTENTION!

Des dommages causés par un inversement des polarités ne sont pas couverts par la garantie.

### Use of External Fuse in DC Input Circuit

Use Class-T or equivalent fuse of appropriate capacity within 7" of the battery Positive terminal. This fuse is required to protect DC input cable run from damage due to short circuit along the length of the cable. Please read instructions under Section 8.4.5 - Installation.

### Hard Wiring of AC Output to AC Panelboards in RVs / Motor Homes / Trailers / Campers



### WARNING!

#### RISK OF ELECTRIC SHOCK

When this unit is installed in RV / Motor Homes / Trailers / Campers and hard-wiring connection is used to feed the AC output of the inverter to the AC Distribution Panelboard / Load Center in the vehicle, it is to be ensured that Ground Fault Circuit Interrupter(s) [GFCI] are installed in the vehicle wiring system to protect branch circuits.

The following GFCIs have been tested to operate satisfactorily and are acceptable. Other types may fail to operate properly when connected to this inverter:

Manufacturer of GFCI	Manufacturer's Model No.	Description
Pass & Seymour	2095 Series	NEMA5-20 Duplex, 20A
Leviton	N7899 Series	NEMA5-20 Duplex, 20A
Zhejiang Trimone	TGM20 Series	NEMA5-20 Duplex, 20A



### MISE EN GARDE! RISQUE DE DÉCHARGE ÉLECTRIQUE

Si l'appareil est installé dans les véhicules récréatifs / camping-cars / caravanes / remorques et est une connexion de câblage est utilisée pour alimenter la puissance CA de l'onduleur au tableau électrique CA du véhicule, il faut assurer qu'un(s) dispositif(s) différentiel(s) à courant résiduel soit installé dans le système de câblage pour protéger les circuits de dérivation.

Les DDR ci-dessous ont été tester, fonctionnent dans une manière satisfaisante. Des autres modèles pourraient échouer s'ils sont branchés à l'onduleur:

Fabricant du DDR	Fabricant's No. de Modèle	Description
Pass & Seymour	Série 2095	NEMA5-20 Duplex de 20A
Leviton	Série N7899	NEMA5-20 Duplex de 20A
Zhejiang Trimone	Série TGM20	NEMA5-20 Duplex de 20A

## SECTION 2 | General Information

### 2.1. DEFINITIONS

The following definitions are used in this manual for explaining various electrical concepts, specifications and operations:

**Peak Value:** It is the maximum value of electrical parameter like voltage / current.

**RMS (Root Mean Square) Value:** It is a statistical average value of a quantity that varies in value with respect to time. For example, a pure sine wave that alternates between peak values of Positive 169.68V and Negative 169.68V has an RMS value of 120 VAC. Also, for a pure sine wave, the RMS value = Peak value  $\div$  1.414.

**Voltage (V), Volts:** It is denoted by "V" and the unit is "Volts". It is the electrical force that drives electrical current (I) when connected to a load. It can be DC (Direct Current – flow in one direction only) or AC (Alternating Current – direction of flow changes periodically). The AC value shown in the specifications is the RMS (Root Mean Square) value.

**Current (I), Amps, A:** It is denoted by "I" and the unit is Amperes – shown as "A". It is the flow of electrons through a conductor when a voltage (V) is applied across it.

**Frequency (F), Hz:** It is a measure of the number of occurrences of a repeating event per unit time. For example, cycles per second (or Hertz) in a sinusoidal voltage.

**Efficiency, ( $\eta$ ):** This is the ratio of Power Output  $\div$  Power Input.

**Phase Angle, ( $\phi$ ):** It is denoted by " $\phi$ " and specifies the angle in degrees by which the current vector leads or lags the voltage vector in a sinusoidal voltage. In a purely inductive load, the current vector lags the voltage vector by Phase Angle ( $\phi$ ) = 90°. In a purely capacitive load, the current vector leads the voltage vector by Phase Angle, ( $\phi$ ) = 90°. In a purely resistive load, the current vector is in phase with the voltage vector and hence, the Phase Angle, ( $\phi$ ) = 0°. In a load consisting of a combination of resistances, inductances and capacitances, the Phase Angle ( $\phi$ ) of the net current vector will be  $> 0^\circ < 90^\circ$  and may lag or lead the voltage vector.

**Resistance (R), Ohm,  $\Omega$ :** It is the property of a conductor that opposes the flow of current when a voltage is applied across it. In a resistance, the current is in phase with the voltage. It is denoted by "R" and its unit is "Ohm" - also denoted as " $\Omega$ ".

**Inductive Reactance ( $X_L$ ), Capacitive Reactance ( $X_C$ ) and Reactance (X):** Reactance is the opposition of a circuit element to a change of electric current or voltage due to that element's inductance or capacitance. Inductive Reactance ( $X_L$ ) is the property of a coil of wire in resisting any change of electric current through the coil. It is proportional to frequency and inductance and causes the current vector to lag the voltage vector by Phase Angle ( $\phi$ ) = 90°. Capacitive reactance ( $X_C$ ) is the property of capacitive elements to oppose changes in voltage.  $X_C$  is inversely proportional to the frequency and capacitance and causes the current vector to lead the voltage vector by Phase Angle ( $\phi$ ) = 90°. The unit of both  $X_L$  and  $X_C$  is "Ohm" - also denoted as " $\Omega$ ". The effects of inductive reac-

## SECTION 2 | General Information

tance  $X_L$  to cause the current to lag the voltage by  $90^\circ$  and that of the capacitive reactance  $X_C$  to cause the current to lead the voltage by  $90^\circ$  are exactly opposite and the net effect is a tendency to cancel each other. Hence, in a circuit containing both inductances and capacitances, the net **Reactance (X)** will be equal to the difference between the values of the inductive and capacitive reactances. The net **Reactance (X)** will be inductive if  $X_L > X_C$  and capacitive if  $X_C > X_L$ .

**Impedance, Z:** It is the vectorial sum of Resistance and Reactance vectors in a circuit.

**Active Power (P), Watts:** It is denoted as "P" and the unit is "Watt". It is the power that is consumed in the resistive elements of the load. A load will require additional Reactive Power for powering the inductive and capacitive elements. The effective power required would be the Apparent Power that is a vectorial sum of the Active and Reactive Powers.

**Reactive Power (Q), VAR:** Is denoted as "Q" and the unit is VAR. Over a cycle, this power is alternatively stored and returned by the inductive and capacitive elements of the load. It is not consumed by the inductive and capacitive elements in the load but a certain value travels from the AC source to these elements in the (+) half cycle of the sinusoidal voltage (Positive value) and the same value is returned back to the AC source in the (-) half cycle of the sinusoidal voltage (Negative value). Hence, when averaged over a span of one cycle, the net value of this power is 0. However, on an instantaneous basis, this power has to be provided by the AC source. *Hence, the inverter, AC wiring and over current protection devices have to be sized based on the combined effect of the Active and Reactive Powers that is called the Apparent Power.*

**Apparent (S) Power, VA:** This power, denoted by "S", is the vectorial sum of the Active Power in Watts and the Reactive Power in "VAR". In magnitude, it is equal to the RMS value of voltage "V" X the RMS value of current "A". The Unit is VA. *Please note that Apparent Power VA is more than the Active Power in Watts. Hence, the inverter, AC wiring and over current protection devices have to be sized based on the Apparent Power.*

**Maximum Continuous Running AC Power Rating:** This rating may be specified as "Active Power" in Watts (W) or "Apparent Power" in Volt Amps (VA). It is normally specified in "Active Power (P)" in Watts for Resistive type of loads that have Power Factor =1. Reactive types of loads will draw higher value of "Apparent Power" that is the sum of "Active and Reactive Powers". Thus, AC power source should be sized based on the higher "Apparent Power" Rating in (VA) for all Reactive Types of AC loads. If the AC power source is sized based on the lower "Active Power" Rating in Watts (W), the AC power source may be subjected to overload conditions when powering Reactive Type of loads.

**Surge Power Rating:** During start up, certain loads require considerably higher surge of power for short duration (lasting from tens of millisecs to few seconds) as compared to their Maximum Continuous Running Power Rating. Some examples of such loads are given below:



## SECTION 2 | General Information

- **Electric Motors:** At the moment when an electric motor is powered ON, the rotor is stationary (equivalent to being “Locked”), there is no “Back EMF” and the windings draw a very heavy surge of starting current (Amperes) called “Locked Rotor Amperes” (LRA) due to low DC resistance of the windings. For example, in motor driven loads like Air-conditioning and Refrigeration Compressors and in Well Pumps (using Pressure Tank), the Starting Surge Current / LRA may be as high as 10 times its rated Full Load Amps (FLA) / Maximum Continuous Running Power Rating. The value and duration of the Starting Surge Current / LRA of the motor depends upon the winding design of the motor and the inertia / resistance to movement of mechanical load being driven by the motor. As the motor speed rises to its rated RPM, “Back EMF” proportional to the RPM is generated in the windings and the current draw reduces proportionately till it draws the running FLA / Maximum Continuous Running Power Rating at the rated RPM.
- **Transformers (e.g. Isolation Transformers, Step-up / Step-down Transformers, Power Transformer in Microwave Oven etc.):** At the moment when AC power is supplied to a transformer, the transformer draws very heavy surge of “Magnetization Inrush Current” for a few milliseconds that can reach up to 10 times the Maximum Continuous Rating of the Transformer.
- **Devices like Infrared Quartz Halogen Heaters (also used in Laser Printers) / Quartz Halogen Lights / Incandescent Light Bulbs using Tungsten heating elements:** Tungsten has a very high Positive Temperature Coefficient of Resistance i.e. it has lower resistance when cold and higher resistance when hot. As Tungsten heating element will be cold at the time of powering ON, its resistance will be low and hence, the device will draw very heavy surge of current with consequent very heavy surge of power with a value of up to 8 times the Maximum Continuous Running AC Power.
- **AC to DC Switched Mode Power Supplies (SMPS):** This type of power supply is used as stand-alone power supply or as front end in all electronic devices powered from Utility / Grid e.g. in audio/video/ computing devices and battery chargers (Please see Section 4 for more details on SMPS). When this power supply is switched ON, its internal input side capacitors start charging resulting in very high surge of Inrush Current for a few milliseconds (Please see Fig 4.1). This surge of inrush current / power may reach up to 15 times the Continuous Maximum Running Power Rating. The surge of inrush current / power will, however, be limited by the Surge Power Rating of the AC source.

**Power Factor, (PF):** It is denoted by “PF” and is equal to the ratio of the Active Power (P) in Watts to the Apparent Power (S) in VA. The maximum value is 1 for resistive types of loads where the Active Power (P) in Watts = the Apparent Power (S) in VA. It is 0 for purely inductive or purely capacitive loads. Practically, the loads will be a combination of resistive, inductive and capacitive elements and hence, its value will be  $> 0 < 1$ . Normally it ranges from 0.5 to 0.8 e.g. (i) AC motors (0.4 to 0.8), (ii) Transformers (0.8) (iii) AC to DC Switch Mode Power Supplies (0.5 to 0.6) etc.

**Load:** Electrical appliance or device to which an electrical voltage is fed.

**Linear Load:** A load that draws sinusoidal current when a sinusoidal voltage is fed to it. Examples are, incandescent lamp, heater, electric motor, etc.

## SECTION 2 | General Information

**Non-Linear Load:** A load that does not draw a sinusoidal current when a sinusoidal voltage is fed to it. For example, non-power factor corrected Switched Mode Power Supplies (SMPS) used in computers, audio video equipment, battery chargers, etc.

**Resistive Load:** A device or appliance that consists of pure resistance (like filament lamps, cook tops, toaster, coffee maker etc.) and draws only Active Power (Watts) from the inverter. The inverter can be sized based on the Active Power rating (Watts) of resistive type of loads without creating overload (except for resistive type of loads with Tungsten based heating element like in Incandescent Light Bulbs, Quartz Halogen Lights and Quartz Halogen Infrared Heaters. These require higher starting surge power due to lower resistance value when the heating element is cold).

**Reactive Load:** A device or appliance that consists of a combination of resistive, inductive and capacitive elements (like motor driven tools, refrigeration compressors, microwaves, computers, audio/ video etc.). The Power Factor of this type of load is  $<1$  e.g. AC motors (PF=0.4 to 0.8), Transformers (PF=0.8), AC to DC Switch Mode Power Supplies (PF=0.5 to 0.6) etc. These devices require Apparent Power (VA) from the AC power source. The Apparent Power is a vectorial sum of Active Power (Watts) and Reactive Power (VAR). *The AC power source has to be sized based on the higher Apparent Power (VA) and also based on the Starting Surge Power.*

### 2.2 OUTPUT VOLTAGE WAVEFORMS

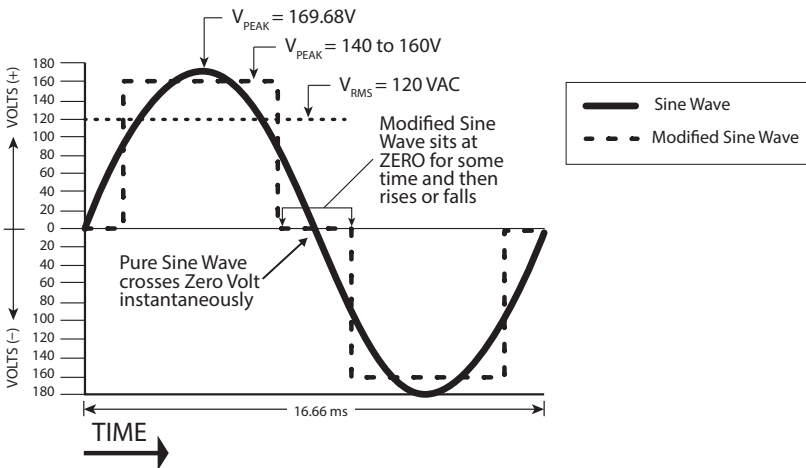

Fig. 2.1: Pure and Modified Sine Waveforms for 120 VAC, 60 Hz

The output waveform of the Samlex PST series inverters is a Pure Sine Wave like the waveform of Utility / Grid Power. Please see Sine Wave represented in the Fig. 2.1 that also shows Modified Sine Waveform for comparison.

## SECTION 2 | General Information

In a Sine Wave, the voltage rises and falls smoothly with a smoothly changing phase angle and also changes its polarity instantly when it crosses 0 Volts. In a Modified Sine Wave, the voltage rises and falls abruptly, the phase angle also changes abruptly and it sits at zero V for some time before changing its polarity. Thus, any device that uses a control circuitry that senses the phase (for voltage / speed control) or instantaneous zero voltage crossing (for timing control) will not work properly from a voltage that has a Modified Sine Waveform.

Also, as the Modified Sine Wave is a form of Square Wave, it is comprised of multiple Sine Waves of odd harmonics (multiples) of the fundamental frequency of the Modified Sine Wave. For example, a 60 Hz Modified Sine Wave will consist of Sine Waves with odd harmonic frequencies of 3rd (180 Hz), 5th (300 Hz), 7th (420 Hz) and so on. The high frequency harmonic content in a Modified Sine Wave produces enhanced radio interference, higher heating effect in inductive loads like microwaves and motor driven devices like hand tools, refrigeration / air-conditioning compressors, pumps etc. The higher frequency harmonics also produce overloading effect in low frequency capacitors due to lowering of their capacitive reactance by the higher harmonic frequencies. These capacitors are used in ballasts for fluorescent lighting for Power Factor improvement and in single-phase induction motors as Start and Run Capacitors. Thus, Modified and Square Wave inverters may shut down due to overload when powering these devices.

### 2.3 ADVANTAGES OF PURE SINE WAVE INVERTERS

- The output waveform is a Sine Wave with very low harmonic distortion and cleaner power like Utility / Grid supplied electricity.
- Inductive loads like microwaves, motors, transformers etc. run faster, quieter and cooler.
- More suitable for powering fluorescent lighting fixtures containing Power Factor Improvement Capacitors and single phase motors containing Start and Run Capacitors
- Reduces audible and electrical noise in fans, fluorescent lights, audio amplifiers, TV, fax and answering machines, etc.
- Does not contribute to the possibility of crashes in computers, weird print outs and glitches in monitors.

### 2.4 SOME EXAMPLES OF DEVICES THAT MAY NOT WORK PROPERLY WITH MODIFIED SINE WAVE AND MAY ALSO GET DAMAGED ARE GIVEN BELOW:

- Laser printers, photocopiers, and magneto-optical hard drives.
- Built-in clocks in devices such as clock radios, alarm clocks, coffee makers, bread-makers, VCR, microwave ovens etc. may not keep time correctly.
- Output voltage control devices like dimmers, ceiling fan / motor speed control may not work properly (dimming / speed control may not function).
- Sewing machines with speed / microprocessor control.

## SECTION 2 | General Information

- Transformer-less capacitive input powered devices like (i) Razors, flashlights, night-lights, smoke detectors etc. (ii) Some re-chargers for battery packs used in hand power tools. *These may get damaged. Please check with the manufacturer of these types of devices for suitability.*
- Devices that use radio frequency signals carried by the AC distribution wiring.
- Some new furnaces with microprocessor control / Oil burner primary controls.
- High intensity discharge (HID) lamps like Metal Halide Lamps. *These may get damaged. Please check with the manufacturer of these types of devices for suitability.*
- Some fluorescent lamps / light fixtures that have Power Factor Correction Capacitors. *The inverter may shut down indicating overload.*
- Induction Cooktops

### 2.5 POWER RATING OF INVERTERS



#### INFO

For proper understanding of explanations given below, please refer to definitions of Active / Reactive / Apparent / Continuous / Surge Powers, Power Factor, and Resistive / Reactive Loads at Section 2.1 under "DEFINITIONS".

The power rating of inverters is specified as follows:

- Maximum Continuous Running Power Rating
- Surge Power Rating to accommodate high, short duration surge of power required during start up of certain AC appliances and devices.

**Please read details of the above two types of power ratings in Section 2.1 under "DEFINITIONS"**



#### INFO

The manufacturers' specification for power rating of AC appliances and devices indicates only the Maximum Continuous Running Power Rating. The high, short duration surge of power required during start up of some specific types of devices has to be determined by actual testing or by checking with the manufacturer. This may not be possible in all cases and hence, can be guessed at best, based on some general Rules of Thumb.

## SECTION 2 | General Information

Table 2.1 provides a list of some common AC appliances / devices that require high, short duration surge of power during start up. An “Inverter Sizing Factor” has been recommended against each which is a Multiplication Factor to be applied to the Maximum Continuous Running Power Rating (Active Power Rating in Watts) of the AC appliance / device to arrive at the Maximum Continuous Running Power Rating of the inverter (Multiply the Maximum Continuous Running Power Rating (Active Power Rating in Watts) of the appliance / device by recommended Sizing Factor to arrive at the Maximum Continuous Running Power Rating of the inverter.

<b>TABLE 2.1: INVERTER SIZING FACTOR</b> <b>Type of Device or Appliance</b>	<b>Inverter Sizing Factor (See note 1)</b>
Air Conditioner / Refrigerator / Freezer (Compressor based)	5
Air Compressor	4
Sump Pump / Well Pump / Submersible Pump	3
Dishwasher / Clothes Washer	3
Microwave (where rated output power is the cooking power)	2
Furnace Fan	3
Industrial Motor	3
Portable Kerosene / Diesel Fuel Heater	3
Circular Saw / Bench Grinder	3
Incandescent / Halogen / Quartz Lamps	3
Laser Printer / Other Devices using Infrared Quartz Halogen Heaters	4
Switch Mode Power Supplies (SMPS): no Power Factor correction	2
Photographic Strobe / Flash Lights	4 (See Note 2)

### NOTES FOR TABLE 2.1

1. Multiply the Maximum Continuous Running Power Rating (Active Power Rating in Watts) of the appliance / device by the recommended Sizing Factor to arrive at the Maximum Continuous Running Power Rating of the inverter.
2. For photographic strobe / flash unit, the Surge Power Rating of the inverter should be > 4 times the Watt Sec rating of photographic strobe / flash unit.

## **SECTION 3 | Limiting Electro-Magnetic Interference (EMI)**

### **3.1 EMI AND FCC COMPLIANCE**

These inverters contain internal switching devices that generate conducted and radiated electromagnetic interference (EMI). The EMI is unintentional and cannot be entirely eliminated. The magnitude of EMI is, however, limited by circuit design to acceptable levels as per limits laid down in North American FCC Standard FCC Part 15(B), Class A. These limits are designed to provide reasonable protection against harmful interference when the equipment is operated *in business / commercial / industrial environments*. These inverters can conduct and radiate radio frequency energy and, if not installed and used in accordance with the instruction manual, may cause harmful interference to radio communications.

### **3.2 REDUCING EMI THROUGH PROPER INSTALLATION**

The effects of EMI will also depend upon a number of factors external to the inverter like proximity of the inverter to the EMI receptors, types and quality of connecting wires and cables etc. EMI due to factors external to the inverter may be reduced as follows:

- Ensure that the inverter is firmly grounded to the ground system of the building or the vehicle
- Locate the inverter as far away from the EMI receptors like radio, audio and video devices as possible
- Keep the DC side wires between the battery and the inverter as short as possible.
- Do NOT keep the battery wires far apart. Keep them taped together to reduce their inductance and induced voltages. This reduces ripple in the battery wires and improves performance and efficiency.
- Shield the DC side wires with metal sheathing / copper foil / braiding:
  - Use coaxial shielded cable for all antenna inputs (instead of 300 ohm twin leads)
  - Use high quality shielded cables to attach audio and video devices to one another
- Limit operation of other high power loads when operating audio / video equipment

## SECTION 4 | Powering Direct / Embedded Switch Mode Power Supplies (SMPS)

### 4.1 CHARACTERISTICS OF SWITCHED MODE POWER SUPPLIES (SMPS)

Switch Mode Power Supplies (SMPS) are extensively used to convert the incoming AC power into various voltages like 3.3V, 5V, 12V, 24V etc. that are used to power various devices and circuits used in electronic equipment like battery chargers, computers, audio and video devices, radios etc. SMPS use large capacitors in their input section for filtration. When the power supply is first turned on, there is a very large inrush current drawn by the power supply as the input capacitors are charged (The capacitors act almost like a short circuit at the instant the power is turned on). The inrush current at turn-on is several to tens of times larger than the rated RMS input current and lasts for a few milliseconds. An example of the input voltage versus input current waveforms is given in Fig. 4.1. It will be seen that the initial input current pulse just after turn-on is > 15 times larger than the steady state RMS current. The inrush dissipates in around 2 or 3 cycles i.e. in around 33 to 50 milliseconds for 60 Hz sine wave.

Further, due to the presence of high value of input filter capacitors, the current drawn by an SMPS (With no Power Factor correction) is not sinusoidal but non-linear as shown in Fig 4.2. The steady state input current of SMPS is a train of non-linear pulses instead of a sinusoidal wave. These pulses are two to four milliseconds duration each with a very high Crest Factor of around 3 (Crest Factor = Peak value ÷ RMS value).

Many SMPS units incorporate "Inrush Current Limiting". The most common method is the NTC (Negative Temperature Coefficient) resistor. The NTC resistor has a high resistance when cold and a low resistance when hot. The NTC resistor is placed in series with the input to the power supply. The cold resistance limits the input current as the input capacitors charge up. The input current heats up the NTC and the resistance drops during normal operation. However, if the power supply is quickly turned off and back on, the NTC resistor will be hot so its low resistance state will not prevent an inrush current event.

The inverter should, therefore, be sized adequately to withstand the high inrush current and the high Crest Factor of the current drawn by the SMPS. Normally, inverters have short duration Surge Power Rating of 2 times their Maximum Continuous Power Rating. *Hence, it is recommended that for purposes of sizing the inverter to accommodate Crest Factor of 3, the Maximum Continuous Power Rating of the inverter should be > 2 times the Maximum Continuous Power Rating of the SMPS. For example, an SMPS rated at 100 Watts should be powered from an inverter that has Maximum Continuous Power Rating of > 200 Watts.*

## SECTION 4 | Powering Direct / Embedded Switch Mode Power Supplies (SMPS)

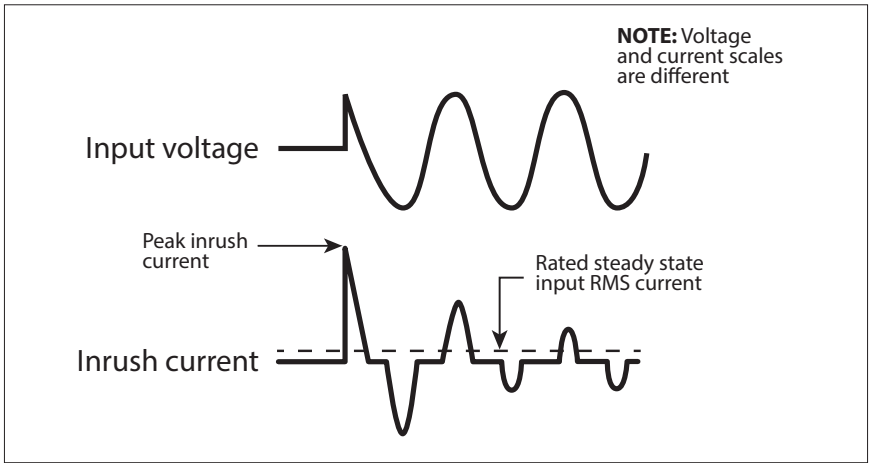

Fig 4.1: Inrush current in an SMPS

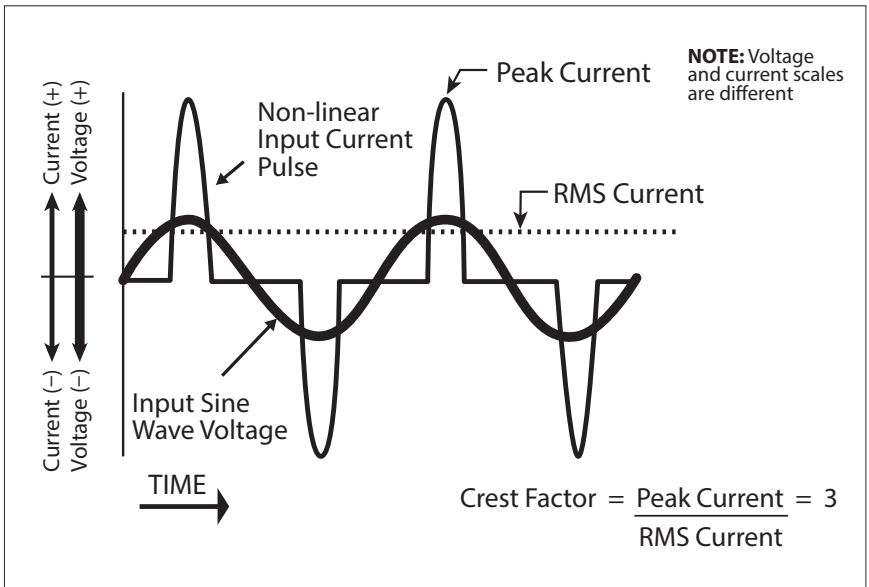

Fig. 4.2: High Crest Factor of current drawn by SMPS



## SECTION 5 | Principle of Operation

### 5.1 GENERAL

These inverters convert DC battery voltage to AC voltage with an RMS (Root Mean Square) value of 120 VAC, 60 Hz RMS.

### 5.2 PURE SINE WAVE OUTPUT WAVEFORM

The waveform of the AC voltage is a pure Sine Waveform that is same as the waveform of Grid / Utility power (*Supplementary information on pure Sine Waveform and its advantages are discussed in Sections 2.2 to 2.4*).

Fig. 5.1 below specifies the characteristics of 120 VAC, 60 Hz pure Sine Waveform. The instantaneous value and polarity of the voltage varies cyclically with respect to time. For example, in one cycle in a 120 VAC, 60 Hz system, it slowly rises in the Positive direction from 0V to a peak Positive value " $V_{\text{peak}} = + 169.68\text{V}$ ", slowly drops to 0V, changes the polarity to Negative direction and slowly increases in the Negative direction to a peak Negative value " $V_{\text{peak}} = - 169.68\text{V}$ " and then slowly drops back to 0V. There are 60 such cycles in 1 sec. Cycles per second is called the "Frequency" and is also termed "Hertz (Hz)". The Time Period of 1 Cycle is 16.66 ms.

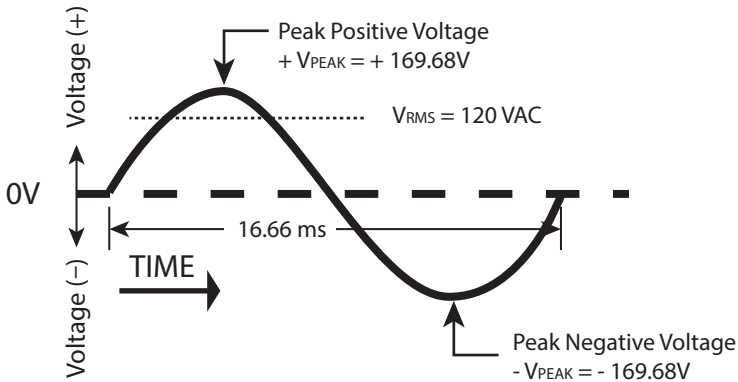

Fig. 5.1: 120 VAC, 60 Hz Pure Sine Waveform

### 5.3 PRINCIPLE OF OPERATION

The voltage conversion takes place in two stages. In the first stage, the DC voltage of the battery is converted to a high voltage DC using high frequency switching and Pulse Width Modulation (PWM) technique. In the second stage, the high voltage DC is converted to 120 VAC, 60 Hz sine wave AC again using PWM technique. This is done by using a special wave shaping technique where the high voltage DC is switched at a high frequency and the pulse width of this switching is modulated with respect to a reference sine wave.

# SECTION 6 | Layout

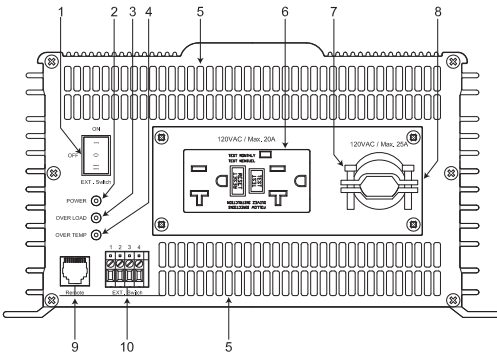

Fig 6.1 (a) PST-3000, Front

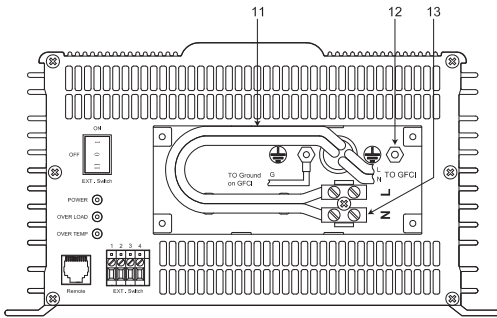

Fig 6.1 (b) PST-3000, Front - Showing compartment with terminals for hardwiring

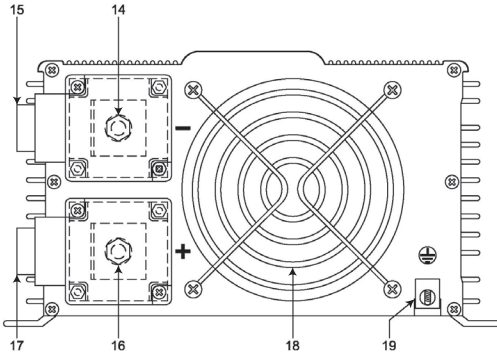
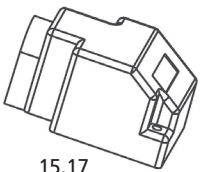

Fig 6.1 (c) PST-3000, Back

1. Three Position Rocker Switch
  - - ON - Push top end to switch ON locally
  - 0 OFF - Centered to switch OFF locally
  - = EXT Switch - Push bottom end to enable switching ON and OFF by external switching control
2. Green LED marked "POWER"
3. Red LED marked "OVER LOAD"
4. RED LED marked "OVER TEMP"
5. Air inlet slots for cooling fan
6. NEMA5-20R GFCI Duplex AC Outlet, 20A maximum
7. Metal strain relief clamp for AC output cable (for hardwiring)
  - Size: Trade Size: 3/4"
  - Wire size accommodated: 3- Conductor "Loomex" cable - AWG #14/3 to AWG #8/3
8. Cover plate for compartment containing L, N and G terminals for hardwiring of AC output to 120VAC Panelboard
9. Modular Jack RJ-50 (10P10C) marked "Remote" for connecting optional wired Remote Control Model RC-300
10. Terminal Block marked "EXT Switch" with 4 terminals for ON / OFF switching using external control signals
11. Compartment containing L, N and G terminals for hardwiring of AC output to 120VAC Panelboard
12. Nut and bolt terminal (size 6x32) for Ground "G" for hardwiring of AC output to 120VAC Panelboard
13. Terminal Block for Line "L" and Neutral "N" terminals for hardwiring of AC output to 120VAC Panelboard
  - Terminal hole diameter: 4.15 mm
  - Terminal set screw size: M3.5
14. Black Negative (-) DC input terminal - Nut and bolt: 5/16 in, 18 TPI
15. Black removable plastic cover for Negative (-) DC input terminal
16. Red Positive (+) DC input terminal - Nut and bolt: 5/16 in, 18 TPI
17. Red removable plastic cover for Positive (+) DC input terminal
18. Opening for air outlet from internal fan (fan is located behind the opening)
19. Chassis Grounding Terminal
  - Hole Diameter: 5/16"
  - Set screw size: 5/16 x 24TPI



15,17

Fig. 6.1: Layout of PST-3000

# SECTION 7 | General Information on Lead Acid Batteries

## 7.1 GENERAL



### INFO

For complete background information on Lead Acid Batteries and charging process, please visit [www.samlexamerica.com](http://www.samlexamerica.com) > support > white papers > White Paper - Batteries, Chargers and Alternators.

Lead-acid batteries can be categorized by the type of application:

1. Automotive service - Starting/Lighting/Ignition (SLI, a.k.a. cranking), and
2. Deep cycle service.

Deep Cycle Lead Acid Batteries of appropriate capacity are recommended for powering of inverters.

## 7.2 DEEP CYCLE LEAD ACID BATTERIES

Deep cycle batteries are designed with thick-plate electrodes to serve as primary power sources, to have a constant discharge rate, to have the capability to be deeply discharged up to 80 % capacity and to repeatedly accept recharging. They are marketed for use in recreation vehicles (RV), boats and electric golf carts – so they may be referred to as RV batteries, marine batteries or golf cart batteries. Use Deep Cycle batteries for powering these inverters.

## 7.3 RATED CAPACITY SPECIFIED IN AMPERE-HOUR (Ah)

Battery capacity “C” is specified in Ampere-hours (Ah). An Ampere is the unit of measurement for electrical current and is defined as a Coulomb of charge passing through an electrical conductor in one second. The Capacity “C” in Ah relates to the ability of the battery to provide a constant specified value of discharge current (also called “C-Rate”: See Section 7.6) over a specified time in hours before the battery reaches a specified discharged terminal voltage (Also called “End Point Voltage”) at a specified temperature of the electrolyte. As a benchmark, the automotive battery industry rates batteries at a discharge current or C-Rate of C/20 Amperes corresponding to 20 Hour discharge period. The rated capacity “C” in Ah in this case will be the number of Amperes of current the battery can deliver for 20 Hours at 80°F (26.7°C) till the voltage drops to 1.75V / Cell. i.e. 10.5V for 12V battery, 21V for 24V battery and 42V for a 48V battery. For example, a 100 Ah battery will deliver 5A for 20 Hours.

## 7.4 RATED CAPACITY SPECIFIED IN RESERVE CAPACITY (RC)

Battery capacity may also be expressed as Reserve Capacity (RC) in minutes typically for automotive SLI (Starting, Lighting and Ignition) batteries. It is the time in minutes a vehicle can be driven after the charging system fails. This is roughly equivalent to the conditions after the alternator fails while the vehicle is being driven at night with the headlights on. The battery alone must supply current to the headlights and the computer/ignition system. The assumed battery load is a constant discharge current of 25A.

## SECTION 7 | General Information on Lead Acid Batteries

Reserve capacity is the time in minutes for which the battery can deliver 25 Amperes at 80°F (26.7°C) till the voltage drops to 1.75V / Cell i.e. 10.5V for 12V battery, 21V for 24V battery and 42V for 48V battery.

Approximate relationship between the two units is:

$$\text{Capacity "C" in Ah} = \text{Reserve Capacity in RC minutes} \times 0.6$$

### 7.5 TYPICAL BATTERY SIZES

The Table 7.1 below shows details of some popular battery sizes:

BCI* Group	Battery Voltage, V	Battery Capacity, Ah
27 / 31	12	105
4D	12	160
8D	12	225
GC2**	6	220

\* Battery Council International; \*\* Golf Cart

### 7.6 SPECIFYING CHARGING / DISCHARGING CURRENTS: C-RATE

Electrical energy is stored in a cell / battery in the form of DC power. The value of the stored energy is related to the amount of the active materials pasted on the battery plates, the surface area of the plates and the amount of electrolyte covering the plates. As explained above, the amount of stored electrical energy is also called the Capacity of the battery and is designated by the symbol "C".

The time in Hours over which the battery is discharged to the "End Point Voltage" for purposes of specifying Ah capacity depends upon the type of application. Let us denote this discharge time in hours by "T". Let us denote the discharge current of the battery as the "C-Rate". If the battery delivers a very high discharge current, the battery will be discharged to the "End Point Voltage" in a shorter period of time. On the other hand, if the battery delivers a lower discharge current, the battery will be discharged to the "End Point Voltage" after a longer period of time. Mathematically:

$$\text{EQUATION 1: Discharge current "C-Rate"} = \text{Capacity "C" in Ah} \div \text{Discharge Time "T"}$$

Table 7.2 below gives some examples of C-Rate specifications and applications:

Hours of discharge time "T" till the "End Point Voltage"	"C-Rate" Discharge Current in Amps = Capacity "C" in Ah ÷ Discharge Time "T" in Hrs.	Example of C-Rate Discharge Currents for 100 Ah battery
0.5 Hrs.	2C	200A
1 Hrs.	1C	100A
5 Hrs. (Inverter application)	C/5 or 0.2C	20A

Table Continues Next Page ▶

## SECTION 7 | General Information on Lead Acid Batteries

Hours of discharge time "T" till the "End Point Voltage"	"C-Rate" Discharge Current in Amps = Capacity "C" in Ah ÷ Discharge Time "T" in Hrs.	Example of C-Rate Discharge Currents for 100 Ah battery
8 Hrs. (UPS application)	C/8 or 0.125C	12.5A
10 Hrs. (Telecom application)	C/10 or 0.1C	10A
20 Hrs. (Automotive application)	C/20 or 0.05C	5A
100 Hrs.	C/100 or 0.01C	1A

**NOTE:** When a battery is discharged over a shorter time, its specified "C-Rate" discharge current will be higher. For example, the "C-Rate" discharge current at 5 Hour discharge period i.e. C/5 Amps will be 4 times higher than the "C-Rate" discharge current at 20 Hour discharge period i.e. C/20 Amps.

### 7.7 CHARGING / DISCHARGING CURVES

Fig. 7.1 shows the charging and discharging characteristics of a typical 12V / 24V Lead Acid battery at electrolyte temperature of 80°F / 26.7°C. The curves show the % State of Charge (X-axis) versus terminal voltage (Y-axis) during charging and discharging at different C-Rates. Please note that X-axis shows % State of Charge. State of Discharge will be = 100% - % State of Charge. These curves will be referred to in the subsequent explanations.

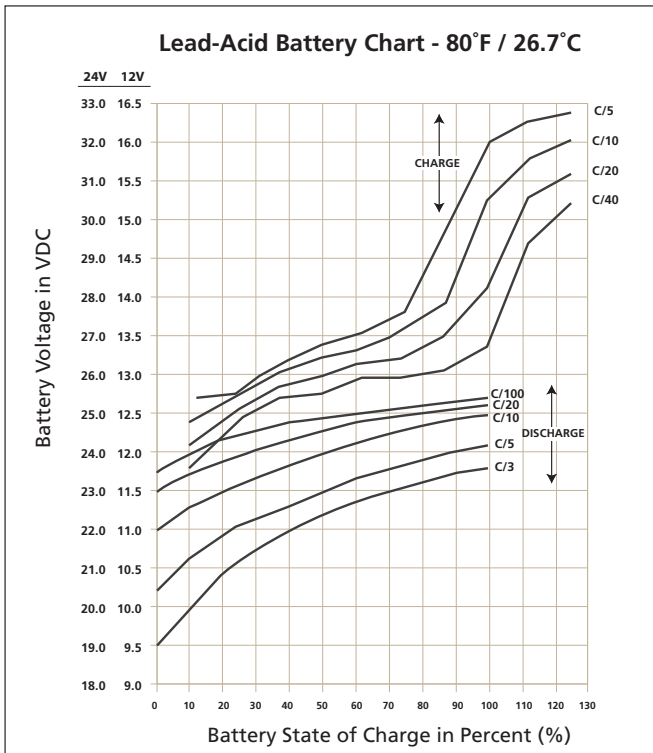

Fig. 7.1: Charging / Discharging Curves for 12V Lead Acid Battery

## SECTION 7 | General Information on Lead Acid Batteries

### 7.8 REDUCTION IN USABLE CAPACITY AT HIGHER DISCHARGE RATES – TYPICAL IN INVERTER APPLICATION

As stated above, the rated capacity of the battery in Ah is normally applicable at a discharge rate of 20 Hours. As the discharge rate is increased as in cases where the inverters are driving higher capacity loads, the usable capacity reduces due to "Peukert Effect". This relationship is not linear but is more or less according to the Table 7.3.

C-Rate Discharge Current	Usable Capacity (%)
C/20	100%
C/10	87%
C/8	83%
C/6	75%
C/5	70%
C/3	60%
C/2	50%
1C	40%

Table 7.3 shows that a 100 Ah capacity battery will deliver 100% (i.e. full 100 Ah) capacity if it is slowly discharged over 20 Hours at the rate of 5 Amperes (50W output for a 12V inverter and 100W output for a 24V inverter). However, if it is discharged at a rate of 50 Amperes (500W output for a 12V inverter and 1000W output for a 24V inverter) then theoretically, it should provide  $100 \text{ Ah} \div 50 = 2$  Hours. However, Table 7.3 shows that for 2 Hours discharge rate, the capacity is reduced to 50% i.e. 50 Ah. Therefore, at 50 Ampere discharge rate (500W output for a 12V inverter and 1000W output for a 24V inverter) the battery will actually last for  $50 \text{ Ah} \div 50 \text{ Amperes} = 1$  Hour.

### 7.9 STATE OF CHARGE (SOC) OF A BATTERY – BASED ON "STANDING VOLTAGE"

The "Standing Voltage" of a battery under open circuit conditions (no load connected to it) can approximately indicate the State of Charge (SOC) of the battery. The "Standing Voltage" is measured after disconnecting any charging device(s) and the battery load(s) and letting the battery "stand" idle for 3 to 8 hours before the voltage measurement is taken. Table 7.4 shows the State of Charge versus Standing Voltage for a typical 12V/24V battery system at 80°F (26.7°C).

## SECTION 7 | General Information on Lead Acid Batteries

**TABLE 7.4: STATE OF CHARGE VERSUS STANDING VOLTAGE**

Percentage of Full Charge	Standing Voltage of Individual Cells	Standing Voltage of 12V Battery	Standing Voltage of 24V Battery
100%	2.105V	12.63V	25.26V
90%	2.10V	12.6V	25.20V
80%	2.08V	12.5V	25.00V
70%	2.05V	12.3V	24.60V
60%	2.03V	12.2V	24.40V
50%	2.02V	12.1V	24.20V
30%	1.97V	11.8V	23.60V
20%	1.95V	11.7V	23.40V
10%	1.93V	11.6V	23.20V
0%	= / < 1.93V	= / < 11.6V	= / < 23.20V

Check the individual cell voltages / specific gravity. If the inter cell voltage difference is more than a 0.2V, or the specific gravity difference is 0.015 or more, the cells will require equalization. *Please note that only the non-sealed / vented / flooded / wet cell batteries are equalized. Do not equalize sealed / VRLA type of AGM or Gel Cell Batteries.*

### 7.10 STATE OF DISCHARGE OF A LOADED BATTERY – LOW BATTERY / DC INPUT VOLTAGE ALARM AND SHUTDOWN IN INVERTERS

Most inverter hardware estimate the State of Discharge of the loaded battery by measuring the voltage at the inverter’s DC input terminals (considering that the DC input cables are thick enough to allow a negligible voltage drop between the battery and the inverter).

Inverters are provided with a buzzer alarm to warn that the loaded battery has been deeply discharged to around 80% of the rated capacity. *Normally, the buzzer alarm is triggered when the voltage at the DC input terminals of the inverter has dropped to around 10.5V for a 12V battery or 21V for 24V battery at C-Rate discharge current of C/5 Amps and electrolyte temp. of 80°F.* The inverter is shut down if the terminal voltage at C/5 discharge current falls further to 10V for 12V battery (20V for 24V battery).

The State of Discharge of a battery is estimated based on the measured terminal voltage of the battery. The terminal voltage of the battery is dependent upon the following:

- **Temperature of the battery electrolyte:** Temperature of the electrolyte affects the electrochemical reactions inside the battery and produces a Negative Voltage Coefficient – during charging / discharging, the terminal voltage drops with rise in temperature and rises with drop in temperature
- **The amount of discharging current or “C-Rate”:** A battery has non linear internal resistance and hence, as the discharge current increases, the battery terminal voltage decreases non-linearly

## SECTION 7 | General Information on Lead Acid Batteries

The discharge curves in Fig. 7.1 show the % State of Charge versus the terminal voltage of typical battery under different charge /discharge currents, i.e. "C-Rates" and fixed temperature of 80°F. (Please note that the X-Axis of the curves shows the % of State of Charge. The % of State of Discharge will be 100% - % State of Charge).

### 7.11 LOW DC INPUT VOLTAGE ALARM IN INVERTERS

As stated earlier, the buzzer alarm is triggered when the voltage at the DC input terminals of the inverter has dropped to around 10.5V for a 12V battery (21V for 24V battery) at C-Rate discharge current of C/5 Amps. Please note that the terminal voltage relative to a particular of State Discharge decreases with the rise in the value of the discharge current. For example, terminal voltages for a State of Discharge of 80% (State of Charge of 20%) for various discharge currents will be as given at Table 7.5 (Refer to Fig 7.1 for parameters and values shown in Table 7.5):

Discharge Current: C-Rate	Terminal Voltage at 80% State of Discharge (20% SOC)		Terminal Voltage When Completely Discharged (0% SOC)	
	12V	24V	12V	24V
	C/3 A	10.45V	20.9V	09.50V
C/5 A	10.90V	21.8V	10.30V	20.6V
C/10 A	11.95V	23.9V	11.00V	22.0V
C/20 A	11.85V	23.7V	11.50V	23.0V
C/100 A	12.15V	24.3V	11.75V	23.5V

In the example given above, the 10.5V / 21.0V Low Battery / DC Input Alarm would trigger at around 80% discharged state (20% SOC) when the C-Rate discharge current is C/5 Amps. However, for lower C-Rate discharge current of C/10 Amps and lower, the battery will be almost completely discharged when the alarm is sounded. **Hence, if the C-Rate discharge current is lower than C/5 Amps, the battery may have completely discharged by the time the Low DC Input Alarm is sounded.**

### 7.12 LOW DC INPUT VOLTAGE SHUT-DOWN IN INVERTERS

As explained above, at around 80% State of Discharge of the battery at C-Rate discharge current of around C/5 Amps, the Low DC Input Voltage Alarm is sounded at around 10.5V for a 12V battery (at around 21V for 24V battery) to warn the user to disconnect the battery to prevent further draining of the battery. If the load is not disconnected at this stage, the batteries will be drained further to a lower voltage and to a completely discharged condition that is harmful for the battery and for the inverter.

Inverters are normally provided with a protection to shut down the output of the inverter if the DC voltage at the input terminals of the inverter drops below a threshold of around 10V for a 12V battery (20V for 24V battery). Referring to the Discharge Curves given in Fig 7.1, the State of Discharge for various C-Rate discharge currents for battery voltage of 10V / 20V is as follows: (Please note that the X-Axis of the curves shows the % of State of Charge. The % of State of Discharge will be 100% - % State of Charge):



## SECTION 7 | General Information on Lead Acid Batteries

- 85% State of Discharge (15% State of Charge) at very high C-rate discharge current of C/3 Amps.
- 100% State of Discharge (0 % State of Charge) at high C-Rate discharge current of C/5 Amps.
- 100% discharged (0% State of charge) at lower C-rate Discharge current of C/10 Amps.

It is seen that at DC input voltage of 10V / 20V, the battery is completely discharged for C-rate discharge current of C/5 and lower.

*In view of the above, it may be seen that a fixed Low DC Input Voltage Alarm is not useful.* Temperature of the battery further complicates the situation. All the above analysis is based on battery electrolyte temperature of 80°F. The battery capacity varies with temperature. Battery capacity is also a function of age and charging history. Older batteries have lower capacity because of shedding of active materials, sulfation, corrosion, increasing number of charge / discharge cycles etc. Hence, the State of Discharge of a battery under load cannot be estimated accurately. However, the low DC input voltage alarm and shut-down functions are designed to protect the inverter from excessive current drawn at the lower voltage.

### 7.13 USE OF EXTERNAL PROGRAMMABLE LOW VOLTAGE DISCONNECTS

The above ambiguity can be removed by using an external, programmable Low Voltage Disconnect where more exact voltage threshold can be set to disconnect the battery based on the actual application requirements. Please consider using the following Programmable Low Battery Cut-off / "Battery Guard" Models manufactured by Samlex America, Inc. [www.samlexamerica.com](http://www.samlexamerica.com)

- BG-40 (40A) – For up to 400W, 12V inverter or 800W, 24V inverter
- BG-60 (60A) - For up to 600W, 12V inverter or 1200W, 24V inverter
- BG-200 (200A) - For up to 2000W, 12V inverter or 4000W, 24V inverter

### 7.14 DEPTH OF DISCHARGE OF BATTERY AND BATTERY LIFE

The more deeply a battery is discharged on each cycle, the shorter the battery life. Using more batteries than the minimum required will result in longer life for the battery bank. A typical cycle life chart is given in the Table 7.6:

Depth of Discharge % of Ah Capacity	Cycle Life of Group 27 /31	Cycle Life of Group 8D	Cycle Life of Group GC2
10	1000	1500	3800
50	320	480	1100
80	200	300	675
100	150	225	550

**NOTE:** It is recommended that the depth of discharge should be limited to 50%.

# SECTION 7 | General Information on Lead Acid Batteries

## 7.15 SERIES AND PARALLEL CONNECTION OF BATTERIES

### 7.15.1 Series Connection

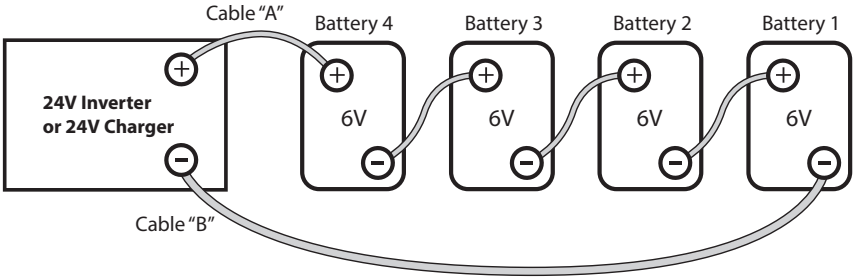

Fig 7.2: Series Connection

When two or more batteries are connected in series, their voltages add up but their Ah capacity remains the same. Fig. 7.2 shows 4 pieces of 6V, 200 Ah batteries connected in series to form a battery bank of 24V with a capacity of 200 Ah. The Positive terminal of Battery 4 becomes the Positive terminal of the 24V bank. The Negative terminal of Battery 4 is connected to the Positive terminal of Battery 3. The Negative terminal of Battery 3 is connected to the Positive terminal of Battery 2. The Negative terminal of Battery 2 is connected to the Positive terminal of Battery 1. The Negative terminal of Battery 1 becomes the Negative terminal of the 24V battery bank.

### 7.15.2 Parallel Connection

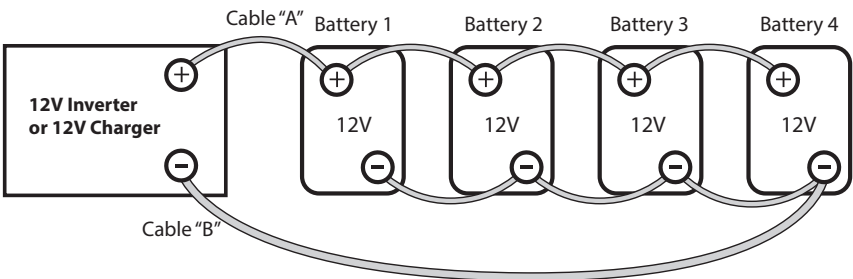

Fig 7.3: Parallel Connection

When two or more batteries are connected in parallel, their voltage remains the same but their Ah capacities add up. Fig. 7.3 shows 4 pieces of 12V, 100 Ah batteries connected in parallel to form a battery bank of 12V with a capacity of 400 Ah. The four Positive terminals of Batteries 1 to 4 are paralleled (connected together) and this common Positive connection becomes the Positive terminal of the 12V bank. Similarly, the four Negative terminals of Batteries 1 to 4 are paralleled (connected together) and this common Negative connection becomes the Negative terminal of the 12V battery bank.

## SECTION 7 | General Information on Lead Acid Batteries

### 7.15.3 Series – Parallel Connection

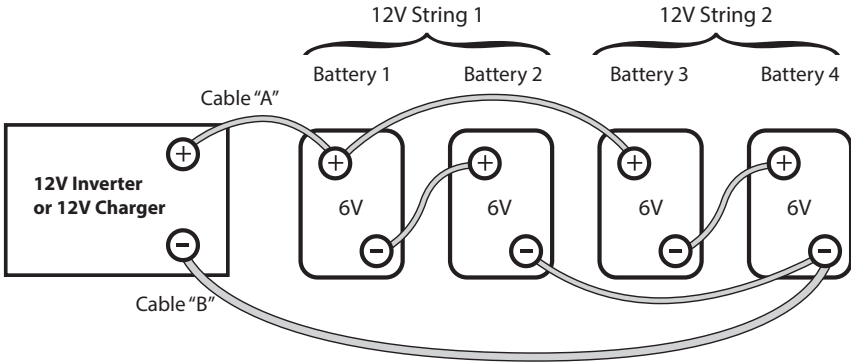

Fig. 7.4: Series-Parallel Connection

Figure 7.4 shows a series – parallel connection consisting of four 6V, 200 AH batteries to form a 12V, 400 Ah battery bank. Two 6V, 200 Ah batteries, Batteries 1 and 2 are connected in series to form a 12V, 200 Ah battery (String 1). Similarly, two 6V, 200 Ah batteries, Batteries 3 and 4 are connected in series to form a 12V, 200 Ah battery (String 2). These two 12V, 200 Ah Strings 1 and 2 are connected in parallel to form a 12V, 400 Ah bank.



#### CAUTION!

When 2 or more batteries / battery strings are connected in parallel and are then connected to an inverter or charger (See Figs 7.3 and 7.4), attention should be paid to the manner in which the charger / inverter is connected to the battery bank. Please ensure that if the Positive output cable of the battery charger / inverter (Cable "A") is connected to the Positive battery post of the first battery (Battery 1 in Fig 7.3) or to the Positive battery post of the first battery string (Battery 1 of String 1 in Fig. 7.4), then the Negative output cable of the battery charger / inverter (Cable "B") should be connected to the Negative battery post of the last battery (Battery 4 as in Fig. 7.3) or to the Negative Post of the last battery string (Battery 4 of Battery String 2 as in Fig. 7.4). This connection ensures the following:

- The resistances of the interconnecting cables will be balanced.
- All the individual batteries / battery strings will see the same series resistance.
- All the individual batteries will charge / discharge at the same charging current and thus, will be charged to the same state at the same time.
- None of the batteries will see an overcharge condition.

## SECTION 7 | General Information on Lead Acid Batteries



### ATTENTION!

Lorsque deux ou plusieurs batteries / chaîne de batteries sont connectés en parallèle et sont ensuite connectés à un onduleur ou un chargeur (voir les figures 7.3 et 7.4), l'attention devrait être accordée à la manière dont le chargeur / onduleur est connecté à la banque de la batterie. S'il vous plaît assurez-vous que si le câble de sortie positive de la batterie / onduleur (câble "A") est relié à la borne positive de la batterie de la première batterie (batterie 1 à la figure 7.3) ou à la borne positive de la batterie de la première chaîne de la batterie ( Batterie 1 of String 1 dans la Fig. 7.4), le câble de sortie négative du chargeur de batterie / onduleur (câble "B") doit être connecté au poste négative de la batterie de la dernière batterie (batterie 4 comme dans la figure 7.3) ou à la borne négative de la dernière chaîne de la batterie (batterie 4 de la chaîne Batterie 2 comme dans la Figure 7.4). Cette connexion assure le suivant:

- La résistance des câbles d'interconnexion sera équilibrée.
- Toutes les batteries / chaîne de batteries individuelles verront la même résistance en série.
- Toutes les batteries individuelles seront chargé/ déchargé au même courant de charge et donc, sera chargé au même état au même moment.
- Aucun des batteries verront un état de surcharge.

### 7.16 SIZING THE INVERTER BATTERY BANK

One of the most frequently asked questions is, "how long will the batteries last?" This question cannot be answered without knowing the size of the battery system and the load on the inverter. Usually this question is turned around to ask "How long do you want your load to run?", and then specific calculation can be done to determine the proper battery bank size.

There are a few basic formulae and estimation rules that are used:

1. Active Power in Watts (W) = Voltage in Volts (V) x Current in Amperes (A) x Power Factor.
2. For an inverter running from a 12V battery system, the approximate DC current required from the 12V batteries is the AC power delivered by the inverter to the load in Watts (W) divided by 10 & for an inverter running from a 24V battery system, the approximate DC current required from the 24V batteries is the AC power delivered by the inverter to the load in Watts (W) divided by 20.
3. Energy required from the battery = DC current to be delivered (A) x Time in Hours (H).

The first step is to estimate the total AC watts (W) of load(s) and for how long the load(s) will operate in hours (H). The AC watts are normally indicated in the electrical nameplate for each appliance or equipment. In case AC watts (W) are not indicated, Formula 1 given above may be used to calculate the AC watts. The next step is to estimate

## SECTION 7 | General Information on Lead Acid Batteries

the DC current in Amperes (A) from the AC watts as per Formula 2 above. An example of this calculation for a 12V inverter is given below:

**Let us say that the total AC Watts delivered by the inverter = 1000W.**

Then, using Formula 2 above, the approximate DC current to be delivered by the 12V batteries =  $1000W \div 10 = 100$  Amperes, or by 24V batteries =  $1000W \div 20 = 50A$ .

**Next, the energy required by the load in Ampere Hours (Ah) is determined.**

For example, if the load is to operate for 3 hours then as per Formula 3 above, the energy to be delivered by the 12V batteries =  $100$  Amperes  $\times$   $3$  Hours =  $300$  Ampere Hours (Ah), or by the 24V batteries =  $50A \times 3$  Hrs =  $150$  Ah.

**Now, the capacity of the batteries is determined based on the run time and the usable capacity.**

From Table 7.3 "Battery Capacity versus Rate of Discharge", the usable capacity at 3 Hour discharge rate is 60%. Hence, the actual capacity of the 12V batteries to deliver 300 Ah will be equal to:  $300 \text{ Ah} \div 0.6 = 500$  Ah, and the actual capacity of the 24V battery to deliver 150 Ah will be equal to  $150 \text{ Ah} \div 0.6 = 250$  Ah.

**And finally, the actual desired rated capacity of the batteries is determined** based on the fact that normally only 80% of the capacity will be available with respect to the rated capacity due to non availability of ideal and optimum operating and charging conditions. So the final requirements will be equal to:

FOR 12V BATTERY:

$500 \text{ Ah} \div 0.8 = 625$  Ah (note that the actual energy required by the load was 300 Ah).

FOR 24V BATTERY:

$250 \text{ Ah} \div 0.8 = 312.5$  Ah (Note that the actual energy required was 150 Ah).

It will be seen from the above that the final rated capacity of the batteries is almost 2 times the energy required by the load in Ah. **Thus, as a Rule of Thumb, the Ah capacity of the batteries should be twice the energy required by the load in Ah.**

### 7.17 CHARGING BATTERIES

Batteries can be charged by using good quality AC powered battery charger or from alternative energy sources like solar panels, wind or hydro systems. Make sure an appropriate Battery Charge Controller is used. It is recommended that batteries may be charged at 10% to 13% of their Ah capacity (Ah capacity based on C-Rate of 20 Hr Discharge Time). Also, for complete charging (return of 100% capacity) of Sealed Lead Acid Battery, it is recommended that a 3 Stage Charger may be used (Constant Current Bulk Charging Stage ▶ Constant Voltage Boost / Absorption Charging ▶ Constant Voltage Float Charging).

In case, Wet Cell / Flooded Batteries are being used, a 4-stage charger is recommended (Constant Current Bulk Charging Stage ▶ Constant Voltage Boost / Absorption Stage ▶ Constant Voltage Equalization Stage ▶ Constant Voltage Float Stage).

## SECTION 8 | Installation



### WARNING!

1. Before commencing installation, please read the safety instructions explained in Section 1 titled “Safety Instructions”.
2. It is recommended that the installation should be undertaken by a qualified, licensed / certified electrician.
3. Various recommendations made in this manual on installation will be superseded by the National / Local Electrical Codes related to the location of the unit and the specific application.

### 8.1 LOCATION OF INSTALLATION

Please ensure that the following requirements are met:

**Working Environment:** Indoor use.

**Cool:** Heat is the worst enemy of electronic equipment. Hence, please ensure that the unit is installed in a cool area that is also protected against heating effects of direct exposure to the sun or to the heat generated by other adjacent heat generating devices.

**Well Ventilated:** The unit is cooled by convection and by forced air-cooling by temperature controlled fan. The fan draws cool air from air intake openings on the front (5, Fig 6.1a) and expels hot air through the exhaust openings next to the fan (18, Fig 6.1c). To avoid shut down of the inverter due to over temperature, do not cover or block these intake / exhaust openings or install the unit in an area with limited airflow. Keep a minimum clearance of 10” around the unit to provide adequate ventilation. If installed in an enclosure, openings must be provided in the enclosure, directly opposite to the air intake and exhaust openings of the inverter.

**Dry:** There should be no risk of condensation, water or any other liquid that can enter or fall on the unit.

**Clean:** The area should be free of dust and fumes. Ensure that there are no insects or rodents. They may enter the unit and block the ventilation openings or short circuit electrical circuits inside the unit.

**Protection Against Fire Hazard:** The unit is not ignition protected and should not be located under any circumstance in an area that contains highly flammable liquids like gasoline or propane as in an engine compartment with gasoline-fueled engines. Do not keep any flammable / combustible material (i.e., paper, cloth, plastic, etc.) near the unit that may be ignited by heat, sparks or flames.

**Closeness to the Battery Bank:** Locate the unit as close to the battery bank as possible to prevent excessive voltage drop in the battery cables and consequent power loss and reduced efficiency. However, the unit should not be installed in the same compartment as the batteries (flooded or wet cell) or mounted where it will be exposed to corrosive acid fumes and

## SECTION 8 | Installation

flammable Oxygen and Hydrogen gases produced when the batteries are charged. The corrosive fumes will corrode and damage the unit and if the gases are not ventilated but allowed to collect, they could ignite and cause an explosion.

**Accessibility:** Do not block access to the front panel. Also, allow enough room to access the AC receptacles and DC wiring terminals and connections, as they will need to be checked and tightened periodically.

**Preventing Radio Frequency Interference (RFI):** The unit uses high power switching circuits that generate RFI. This RFI is limited to the required standards. Locate any electronic equipment susceptible to radio frequency and electromagnetic interference as far away from the inverter as possible. *Read Section 3 "Limiting Electromagnetic Interference (EMI)" for additional information.*

### 8.2 OVERALL DIMENSIONS

The overall dimensions and the location of the mounting slots are shown in Fig. 8.1.

### 8.3 MOUNTING ORIENTATION

The unit has air intake and exhaust openings for the cooling fan. It has to be mounted in such a manner so that small objects should not be able to fall easily into the unit from these openings and cause electrical / mechanical damage. Also, the mounting orientation should be such that if the internal components overheat and melt / dislodge due to a catastrophic failure, the melted / hot dislodged portions should not be able to fall out of the unit on to a combustible material and cause a fire hazard. The size of openings has been limited as per the safety requirements to prevent the above possibilities when the unit is mounted in the recommended orientations. In order to meet the regulatory safety requirements, the mounting has to satisfy the following requirements:

- Mount on a non-combustible material.
- The mounting surface should be able to support the weight of the unit
- Mount horizontally on a horizontal surface - above a horizontal surface (e.g. table top or a shelf).
- Mount horizontally on a vertical surface – The unit can be mounted on a vertical surface (like a wall) with the fan axis horizontal (fan opening facing left or right).



#### **WARNING!**

Mounting the unit vertically on a vertical surface is NOT recommended (fan opening facing up or down). As explained above, this is to prevent falling of objects into the unit through the fan opening when the fan opening faces up. If fan opening faces down, hot damaged component may fall out.

The surface of the unit is likely to be at an elevated temperature in conditions of higher load and higher ambient temperature. Hence, the unit should be installed in a manner where it is not likely to come in contact with any person.

# SECTION 8 | Installation

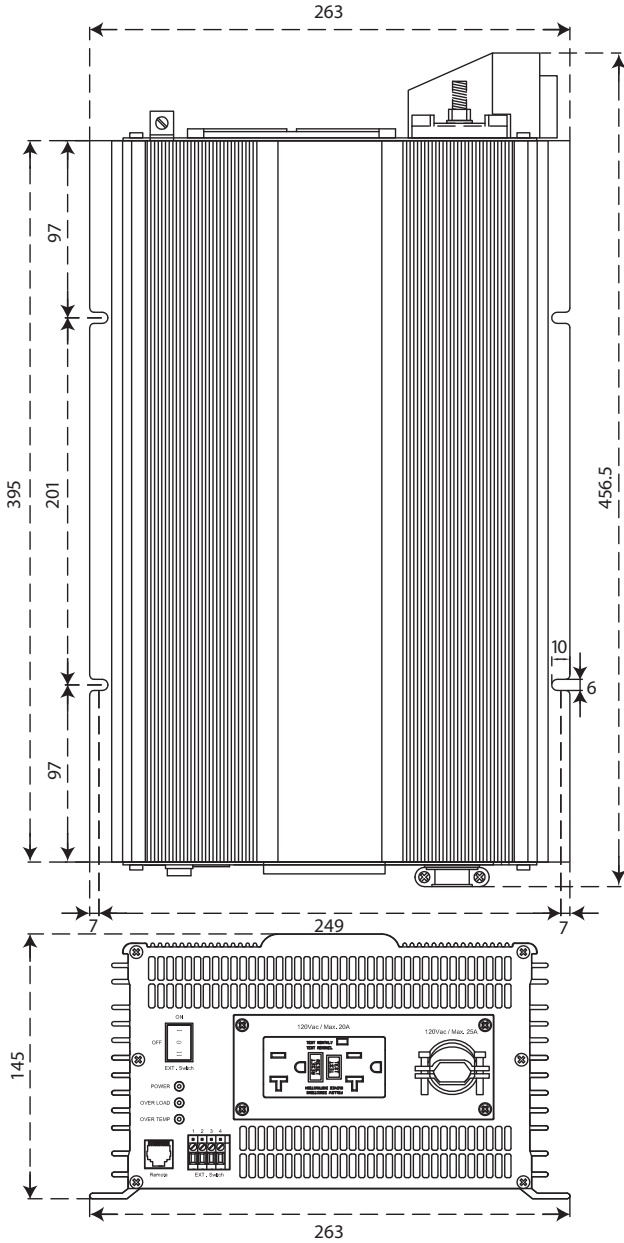

**NOTE:** Dimensions are in mm

Fig. 8.1: PST-3000 Overall Dimensions & Mounting Slots



## SECTION 8 | Installation

### 8.4 DC SIDE CONNECTIONS

#### 8.4.1 Preventing DC Input Over Voltage

It is to be ensured that the DC input voltage of this unit does not exceed 16.5 VDC for PST-3000-12 and 33.0 VDC for PST-3000-24 to prevent permanent damage to the unit. Please observe the following precautions:

- Ensure that the maximum charging voltage of the external battery charger / alternator / solar charge controller does not exceed 16.5 VDC for PST-3000-12 and 33.0 VDC for PST-3000-24
- Do not use unregulated solar panels to charge the battery connected to this unit. Under open circuit conditions and in cold ambient temperatures, the output of the solar panel may be > 22 VDC for 12V nominal panel and > 44V for 24V nominal panel. Always use a charge controller between the solar panel and the battery.
- When using Diversion Charge Control Mode in a charge controller, the solar / wind / hydro source is directly connected to the battery bank. In this case, the controller will divert excess current to an external load. As the battery charges, the diversion duty cycle will increase. When the battery is fully charged, all the source energy will flow into the diversion load if there are no other loads. The charge controller will disconnect the diversion load if the current rating of the controller is exceeded. Disconnection of the diversion load may damage the battery as well as the inverter or other DC loads connected to the battery due to high voltages generated during conditions of high winds (for wind generators), high water flow rates (for hydro generators). It is, therefore, to be ensured that the diversion load is sized correctly to prevent the above over voltage conditions.
- Do not connect this unit to a battery system with a voltage higher than the rated battery input voltage of the unit (e.g. do not connect PST-3000-12 to 24V or 48V Battery System)

#### 8.4.2 Preventing Reverse Polarity on the DC Input Side



##### **CAUTION!**

Damage caused by reverse polarity is not covered by warranty! When making battery connections on the input side, make sure that the polarity of battery connections is correct (Connect the Positive of the battery to the Positive terminal of the unit and the Negative of the battery to the Negative terminal of the unit). If the input is connected in reverse polarity, DC fuse(s) inside the inverter will blow and may also cause permanent damage to the inverter.

## SECTION 8 | Installation

### 8.4.3 Connection from Batteries to the DC Input Side – Sizing of Cables and Fuses



#### CAUTION!

The input section of the inverter has large value capacitors connected across the input terminals. As soon as the DC input connection loop (Battery (+) terminal → External Fuse → Positive input terminal of EVO → Negative input terminal of the EVO → Battery (-) terminal) is completed, these capacitors will start charging and the unit will **momentarily** draw very heavy current to charge these capacitors that will produce sparking on the last contact in the input loop even when the unit is in powered down condition. Ensure that the fuse is inserted only after all the connections in the loop have been completed so that sparking is limited to the fuse area.

Flow of electric current in a conductor is opposed by the resistance of the conductor. The resistance of the conductor is directly proportional to the length of the conductor and inversely proportional to its cross-section (thickness). The resistance in the conductor produces undesirable effects of voltage drop and heating. The size (thickness / cross-section) of the conductors is designated by AWG (American Wire Gauge). Conductors thicker than AWG #4/0 are sized in MCM/kcmil. Table 8.1 below gives Resistance in Ohm ( $\Omega$ ) per Foot at 25°C / 77°F for the wire sizing recommended for use with this inverter.

WIRE SIZE, AWG	RESISTANCE IN OHM ( $\Omega$ ) PER FOOT AT 25°C / 77°F
AWG#2	0.000159 $\Omega$ per Foot
AWG#1/0	0.000096 $\Omega$ per Foot
AWG#2/0	0.000077 $\Omega$ per Foot
AWG#4/0	0.000050 $\Omega$ per Foot

Conductors are protected with insulating material rated for specific temperature e.g. 105°C/221°F. As current flow produces heat that affects insulation, there is a maximum permissible value of current (called “Ampacity”) for each size of conductor based on temperature rating of its insulation. The insulating material of the cables will also be affected by the elevated operating temperature of the terminals to which these are connected. Ampacity of cables is based on UL-458 and the National Electrical Code (NEC)-2014. Please see details given under “Notes for Table 8.2”.

The DC input circuit is required to handle very large DC currents and hence, the size of the cables and connectors should be selected to ensure minimum voltage drop between the battery and the inverter. Thinner cables and loose connections will result in poor inverter performance and will produce abnormal heating leading to risk of insulation melt down and fire. Normally, the thickness of the cable should be such that the voltage drop due to the current & the resistance of the length of the cable should be less than 2% to 5%. Use

## SECTION 8 | Installation

oil resistant, multi-stranded copper wire cables rated at 105°C / 77°F minimum. Do not use aluminum cable as it has higher resistance per unit length. Cables can be bought at a marine / welding supply store. Effects of low voltage on common electrical loads are given below:

- **Lighting circuits** - incandescent and Quartz Halogen: A 5% voltage drop causes an approximate 10% loss in light output. This is because the bulb not only receives less power, but the cooler filament drops from white-hot towards red-hot, emitting much less visible light.
- **Lighting circuits** - fluorescent: Voltage drop causes a nearly proportional drop in light output.
- **AC induction motors** - These are commonly found in power tools, appliances, well pumps etc. They exhibit very high surge demands when starting. Significant voltage drop in these circuits may cause failure to start and possible motor damage.
- **PV battery charging circuits** - These are critical because voltage drop can cause a disproportionate loss of charge current to charge a battery. A voltage drop greater than 5% can reduce charge current to the battery by a much greater percentage.

### 8.4.4 Fuse Protection in the Battery Circuit

A battery is an **unlimited** source of current. Under short circuit conditions, a battery can supply thousands of Amperes of current. If there is a short circuit along the length of the cables that connects the battery to the inverter, thousands of Amperes of current can flow from the battery to the point of shorting and that section of the cable will become red-hot, the insulation will melt and the cable will ultimately break. This interruption of very high current will generate a hazardous, high temperature, high-energy arc with accompanying high-pressure wave that may cause fire, damage nearby objects and cause injury. To prevent occurrence of hazardous conditions under short circuit conditions, the fuse used in the battery circuit should limit the current (should be "Current Limiting Type"), blow in a very short time (should be Fast Blow Type) and at the same time, quench the arc in a safe manner. For this purpose, **UL Class T Fuse** or equivalent should be used (As per UL Standard 248-15). This special purpose current limiting, very fast acting fuse will blow in less than 8 ms under short circuit conditions. **Appropriate capacity of the above Class T fuse or equivalent should be installed within 7" of the battery Plus (+) Terminal** (Please see Table 8.2 for fuse sizing). Marine Rated Battery Fuses, MRBF-xxx Series made by Cooper Bussmann may also be used. These fuses comply with ISO 8820-6 for road vehicles.



#### **WARNING!**

Use of an appropriately sized external fuse as described above is **mandatory** to provide safety against fire hazard due to accidental short circuit in the battery cables. Please note that the internal DC side fuses are designed to protect their internal components of the inverter against DC side overloading. These fuses will **NOT** blow if there is a short circuit along the length of wires connecting the battery and the inverter.

## SECTION 8 | Installation

### 8.4.5 Recommended Sizes of Battery Cables and Fuses

Sizes of cables and fuses are shown in Table 8.2. Sizing is based on safety considerations specified in UL-458, NEC-2014 and ISO-10133. Please refer to "Notes for Table 8.2" for details.

Model No.	Maximum Continuous DC Input Current (See Note 1)	Minimum Ampacity of cable as per NEC (See Note 2)	Maximum External Battery Fuse Size (Based on Column 2) (See Note 3)	Minimum cable size (See Note 4)			Part No. of Recommended Samlex America Inverter Installation Kit (See Note 5)
				3 ft / 0.91M	6 ft / 1.83M	10 ft / 3.05M	
(1)	(2)	(3)	(4)	(5)	(6)	(7)	(8)
PST-3000-12	360A	450A	400A	AWG#4/0	AWG#4/0	2 x AWG#2/0	DC-3500-KIT
PST-3000-24	180A	225A	200A	AWG#2	AWG#2	AWG#1/0	DC-2000-KIT

#### NOTES FOR TABLE 8.2

- 1) Column 2 indicates the rated continuous DC input current drawn from the battery.
- 2) Column 3 indicates minimum NEC Ampacity for sizing of conductors. NEC Ampacity is not less than 125% of the rated continuous DC input current (Column 2) - Refer to NEC-2014 (National Electrical Code) - Section 215.2(A)(1)(a) for Feeder Circuits.
- 3) Column (4) indicates the size of external fuse in the battery circuit. It is mandatory to install this fuse within 7" of the battery Positive terminal to protect the battery cables against short circuit. Amp rating of the fuse is based on the following considerations:
  - a) Not less than the Maximum Continuous DC Input Current (Column 2)
  - b) Closest Standard Ampere Rating of Fuse has been used - Refer to NEC-2014 (National Electrical Code) - Section 240.6(A)
  - c) Where Standard Fuse Rating does not match the required Ampacity (Column 2), the next higher Standard Rating of the fuse has been used - Refer to NEC-2014 (National Electrical Code) - Section 240.4(B)
  - d) **Type of fuse:** Fast-acting, Current Limiting, UL Class T (UL Standard 248-15) or equivalent
- 4) Columns 5 to 7 indicate minimum cable conductor size that is based on the following 2 considerations. **Thicker conductor out of the following 2 considerations has been chosen:**
  - a) As per guidelines in ISO 10133 for 105°C cable insulation and cable running in free air. Conductor size is based on:

## SECTION 8 | Installation

- (i) NEC Ampacity specified at Column 3,
- (ii) Copper conductor with temperature rating of 105°C/221°F and
- (iii) Ambient temperature of 30°C / 86°F b)

b) Voltage drop across the length of cables limited to 2% of 12V / 24V.

- i) Voltage drop has been calculated by multiplying the Rated DC Input Current (Column 2) and the resistance of the total length of Copper conductor (**the total length of conductor has been taken as 2 times the running distance between the unit and the battery to cover 2 lengths of Positive and Negative cable conductors**).

ii) Resistance of the cable is based on Table 8.1.

5) Samlex America, Inc. makes 4 Models of generic / universal Inverter Installation Kits to cover installation requirements of a wide power range from 600W to 3500W for 12V inverters and from 1200W to 7000W for 24V inverters. Please note that the Inverter Installation Kit that has been recommended in Column (8) may include thicker wire size / correspondingly bigger fuse size than those recommended in Table 8.2. This is acceptable.

Fuse in the battery circuit is primarily required for protection against short circuit in the battery cable run. The size of this fuse has to be equal to or larger than the maximum DC input current of the inverter at Column (2). Further, the Amp rating of the fuse used for protecting a battery cable against short circuit has to be lower than the Ampacity of the cable so that the fuse blows before the cable insulation is damaged due to overheating as a result of fault current higher than the Ampacity of the cable. The Amp ratings of fuses provided with the Inverter Installation Kits are lower than the wire size provided with the Kit.

The Kits come with 10ft length of cables to cover battery to inverter distance of up to 10 ft. If the actual cable routing distance from the battery to the inverter is less than 10ft, please cut-off the extra length of cables. This will result in reduction in the overall resistance of the cable / reduction in voltage drop and consequently, will improve the efficiency of the inverter system

### 8.4.6 DC Input Connection

The DC input terminals for battery connection (14 & 16 in Fig. 6.1c) have nut and bolt connection - bolt size is 5/16" (18 Threads per Inch). Use ring tongue type of terminals on the wire ends to fit 5/16" bolt size.

### 8.4.7 Reducing RF Interference

Please comply with recommendations given in Section 3 - "Limiting Electromagnetic Interference".

## SECTION 8 | Installation

### 8.5 AC SIDE CONNECTIONS



#### **WARNING! Preventing Paralleling of the AC Output**

1. The AC output of the inverter cannot be synchronized with another AC source and hence, it is not suitable for paralleling. The AC output of the inverter should never be connected directly to an electrical Panelboard / Load Center which is also fed from the utility power/ generator. Such a connection will result in parallel operation and AC power from the utility / generator will be fed back into the inverter which will instantly damage the output section of the inverter and may also pose a fire and safety hazard. If an electrical Panelboard / Load Center is being fed from the utility power / generator and the inverter is required to feed this panel as backup power source, the AC power from the utility power/ generator and the inverter should first be fed to a manual selector switch / Automatic Transfer Switch and the output of the manual selector switch / Automatic Transfer Switch should be connected to the electrical Panelboard / Load Center.
2. To prevent possibility of paralleling and severe damage to the inverter, never use a simple jumper cable with a male plug on both ends to connect the AC output of the inverter to a handy wall receptacle in the home / RV.

#### **8.5.1 Neutral to Chassis Ground Bond**

The Neutral slots of the NEMA5-20R GFCI Duplex Receptacles (6, Fig 6.1a) and the Neutral Terminal for hardwiring (13, Fig 6.1b) are internally bonded to the metal chassis of the inverter.

#### **8.5.2 AC Output Connection Through Ground Fault Circuit Interrupter (GFCI)**

An un-intentional electric path between a source of current and a grounded surface is referred to as a "Ground Fault". Ground faults occur when current is leaking somewhere. In effect, electricity is escaping to the ground. How it leaks is very important. If your body provides a path to the ground for this leakage (dry human body has a low resistance of only around 1 K Ohm), you could be injured, burned, severely shocked or electrocuted. A Ground Fault Circuit Interrupter (GFCI) protects people from electric shock by detecting leakage and cutting off the AC source.

The AC output of this inverter is available through a NEMA5-20R GFCI Duplex Receptacle (6, Fig 6.1a) and also through hardwiring terminal connections located in a compartment (13, Fig 6.1a) behind the GFCI receptacle. The Neutral slot of this receptacle (longer rectangular slot) and the Neutral Terminal "N" of the Terminal Block for AC output hardwiring (13, Fig 6.1b) are internally bonded to the metal chassis of the inverter.

There is a Green indicator light on the GFCI outlet that will be lighted when the GFCI is operating normally. The light will switch OFF if the GFCI is tripped.

## SECTION 8 | Installation

The GFCI is provided with the following buttons:

- **Reset Button:** In case the GFCI is tripped, it can be reset by pressing the "Reset Button".

**NOTE:** For the Reset Button to operate, the inverter has to be in ON condition and should be outputting AC power to the internal Line Side of the GFCI (no Fault / shut-down condition).

- **Test Button:** This button is used to test if the GFCI is operating normally. Test the GFCI periodically to ensure that it is operating normally.

The GFCI will trip due to the following conditions:

- Leakage or Ground Fault (Leakage of 5 to 6 mA)
- Neutral to Ground bonding (connection) on the load side of the GFCI



### CAUTION!

1. Each of the NEMA5-20R outlets is rated for 16A continuous and 20A intermittent. Do not draw more than this rating from each outlet. For drawing the full rated output capacity of 25A of the inverter, use AC output connections for hardwiring (13, Fig 6.1b) as described at Section 8.5.2 below.
2. Do not feed the output from the GFCI receptacle to a Panelboard / Load Center where the Neutral is bonded to the Earth Ground. This will trip the GFCI. If the AC output is required to be fed to a Panelboard / Load Center, use hardwiring connections (please see details given at Section 8.5.2 below).
3. If an extension cord is used from the GFCI outlet, please ensure that the cord is 2-Pole Grounding Type with NEMA5-15P / NEMA5-20P plug.

### 8.5.3 AC Output Connections for Hardwiring

For connecting the AC output of the inverter to an AC Panelboard / Load Center, separate connections are available for hard wiring. Please refer to Fig 6.1. Compartment (11, Fig 6.1b) contains terminals for AC output. The compartment is covered by Cover Plate (8, Fig 6.1a) with the help of 4 screws. The AC wiring enters through the metal Strain Relief Clamp (7, Fig 6.1a). After the connections have been made, tighten the clamp. AC output connections are as follows:

#### Terminal Block (13, Fig 6.1b) with Line "L" and Neutral "N" Terminals.

Please note that Line terminal "L" of the AC Terminal Block (13, Fig 6.1b) and the Line terminal on the Line side of the GFCI (6, Fig 6.1a) are internally connected together at the PCB. Similarly, Neutral terminal "N" on the AC Terminal Block (13, fig 6.1b) and the Neutral terminal on the Line side of the GFCI (6, Fig 6.1a) are internally connected together at the PCB

- Hole diameter: 4.15 mm / 0.16"
- Set screw: #6 (UNF, 40 Threads per Inch) or M3.5 ( Coarse Pitch 0.6 mm)

## SECTION 8 | Installation

### AC Ground Terminal (12, Fig 6.1b)

- Stud: #6 (UNC, 32 Threads Per Inch)

### Neutral to Chassis Ground Bonding

- Neutral “N” is bonded to the metal chassis of the inverter through a loop of wire connecting the “N” terminal on the Line side of the GFCI to the chassis of the inverter.



#### WARNING!

**RISK OF ELECTRIC SHOCK.** When this unit is installed in vehicles and hard-wiring connection is used to feed the AC output of the inverter to the AC Panel-board / Load Center in the vehicle, it is to be ensured that Ground Fault Circuit Interrupter(s) [GFCI] are installed in the vehicle wiring system to protect all Branch Circuits.

The GFCIs in Table 8.3 have been tested to operate satisfactorily and are acceptable. Other types may fail to operate properly when connected to this inverter:

Mfr. of GFCI	Mfr.'s Model No.	Description
Pass & Seymour	2095 Series	NEMA5-20 Duplex 20A
Leviton	N7899 Series	NEMA5-20 Duplex 20A
Zhejiang Trimone	TGM20 Series	NEMA5-20 Duplex 20A

### 8.5.4 Hard Wiring of AC Output – Sizing of Wiring and Breaker

Sizes of Line and Neutral conductors and breaker are shown in Table 8.4. Sizing is based on safety considerations specified in UL-458 and NEC-2014. Please refer to “Notes for Table 8.4” for details.

**Example of AC cable types:** (a) 12/3, Loomex / Romex (NMD-90) - Non Metallic sheathed; Dry: 90°C. This is a 3-conductor (Insulated Line, Neutral and bare Ground), AWG #12 cable used for residential wiring (b) AC cord types: SE, SEOO, ST, STO, SJ, SJEEO, SJT or SJTO

For firm connection when using set screw type of terminals for connecting stranded wire, use “Cord End Terminals” for termination of the bare Line and Neutral ends of the conductors and “Ring Type of Terminal” for termination of the bare end of Grounding Conductor. For convenience, the following terminals have been provided:

**For Line and Neutral conductors:** 2 pieces of Cord End Terminals for conductor size AWG#12

**For Neutral conductor:** 1 piece of Ring Terminal for #6 stud and for conductor size AWG#12



## SECTION 8 | Installation



### CAUTION!

- (a) Use proper Crimping Tool to crimp the terminals to the bare ends of the conductors.
- (b) Make sure that the AC cable is adequately clamped by the metal Strain Relief Clamp (7, Fig 6.1a)

**Table 8.4 Recommended Sizing of AC Output Wiring and Breaker**

Model No.	Maximum continuous AC output current	Minimum Ampacity of AC output Line and Neutral conductors as per NEC (125% times Column 2)	Maximum size of external AC output Breaker (Based on Column 3)	Minimum size of Line and Neutral conductors based on Ampacity at Column 3 (Ampacity based on conductor temperature of 90°C)
(1)	(2)	(3)	(4)	(5)
PST-3000-12 & 24	25A	31.25	30A	AWG#12

### NOTES FOR TABLE 8.4

- 1) Column 2 indicates the rated continuous AC output current
- 2) Column 3 indicates NEC Ampacity based on which cable conductor size (Column 5) is determined. NEC Ampacity is not less than 125% of the rated continuous AC output current (Column 2) - Refer to NEC-2014 (National Electrical Code) - Section 215.2(A)(1)(a) for Feeder Circuits.
- 3) Column 5 indicates conductor size for the Line and Neutral conductors based on guidelines in NEC-2014 Table 310.15(B)(16) for conductors running in conduit / raceway.
  - (a) NEC Ampacity specified at Column 3 but limited to Breaker size of 30A (Column 4).
  - (b) Copper conductor with temperature rating of minimum 90°C/194°F
  - (c) Ambient temperature of 30°C / 86°F
- 4) Column (4) indicates the maximum size of external AC breaker (30A) based on maximum NEC Ampacity of 30A for AWG#12 insulated copper conductor (Column 5) rated at 90°C / 194°F at 30°C / 86°F ambient – Refer to NEC-2014 Table 310.15(B)(16) for conductors running in conduit / raceway.

## 8.6 GROUNDING TO EARTH OR TO OTHER DESIGNATED GROUND

For safety, ground the metal chassis of the inverter to the Earth Ground or to the other designated ground (For example, in a mobile RV, the metal frame of the RV is normally designated as the Negative DC Ground). A chassis Grounding Lug (19, Fig 6.1c) has been provided for grounding the metal chassis of the inverter to the appropriate ground.

When using the inverter in a building, connect a 10 mm<sup>2</sup> or AWG #8 insulated stranded copper wire from the above equipment grounding lug to the Earth Ground connection ( a connection that connects to the Ground Rod or to buried metallic water pipe or to another connection that is solidly bonded to the Earth Ground ). The connections must be tight against bare metal. Use star washers to penetrate paint and corrosion.

## SECTION 8 | Installation

When using the inverter in a mobile RV, connect a 10 mm<sup>2</sup> or AWG #8 insulated stranded copper wire from the above Chassis Grounding Lug to the Main Grounding Bus Bar of the RV (bonded to the vehicle chassis). The connections must be tight against bare metal. Use star washers to penetrate paint and corrosion.

### 8.7 OPTIONAL WIRED REMOTE CONTROL – MODEL RC-300



#### CAUTION!

For the optional Remote Control RC-300 to operate, the inverter has to be **FIRST** turned **ON** using the following ON / OFF controls:

- a) **When NOT using external 1-Wire or 2-Wire ON / OFF Control:** By pushing the top end (marked “–”) of the 3-Position Rocker Switch (1, Fig 6.1a) to position marked “ON”
- b) **When using external 1-Wire or 2-Wire ON / OFF Controls:** By **FIRST** pushing the bottom end (marked “=”) of the 3-Position Rocker Switch (1, Fig 6.1a) to position marked “EXT. Switch” and **THEN** switching **ON** the inverter by (i) closing the switch or relay contact in 2-Wire ON/OFF Control (Fig 8.2a) or (ii) closing the switch or relay contact in 2-Wire ON/OFF Control using switched DC voltage (Fig 8.2b) or (iii) closing the switch or relay contact in 1-Wire ON/OFF control using switched DC voltage from battery supplying the inverter.

An optional Wired Remote Control Model No. RC-300 (with 25 ft. / 7.62 metre cable), is available for switching ON and switching OFF and monitoring. The remote has LCD display showing AC output V, A, Hz, W, VA and Power Factor. It also has LED indications similar to the indications on the front panel (2, 3, 4 in Fig. 6.1a). The Remote Control is connected to RJ-50 Jack (9, Fig 6.1a). Read Remote Control Manual for details.

### 8.8 ON/OFF CONTROL FROM REMOTE LOCATION USING 2-WIRE OR 1-WIRE EXTERNAL ON/OFF CONTROL



#### CAUTION!

For operation of this function, the 3-Position Rocker Switch on the front panel marked “ON/OFF/EXT. Switch (1, Fig 6.1a) should be **FIRST** pushed at the bottom end (marked “=”) to rock it to the bottom “EXT. Switch” position.

The unit can be switched ON/OFF from a remote location using external, wired ON/OFF control arrangements as shown in Fig 8.2(a), (b) and (c). Details are given below:

- **2-Wire ON/OFF Control from Remote Location Using Switch/Relay Contact, Fig 8.2(a):**  
In this arrangement, external voltage source is NOT required. The inverter will switch ON when the relay contact / switch is closed and terminals 1 and 2 of the Terminal

## SECTION 8 | Installation

Block (10, Fig 6.1a) are shorted. The inverter will switch OFF when the relay contact / switch is opened and short is removed across terminals 1 and 2 of the Terminal Block (10, Fig 6.1a)

- **2-Wire ON/OFF Control Using Switched DC Voltage (10-33VDC), Fig 8.2(b):**



### CAUTION!

1. Please ensure correct polarity of wiring connection. Positive (+) of the external DC source should be connected to Terminal 3 of the Terminal Block (10, Fig 6.1a) and Negative (-) to Terminal 4. In case the polarity is reversed, the ON/OFF control will **NOT** operate. **The input to these terminals is protected against reverse polarity**
2. Use 1A fuse as shown as close to the DC source as possible



### INFO

The 10-30VDC external control signal on terminals 3 and 4 of the Terminal Block (10, Fig 6.1a) feeds to an internal Opto-Isolator. Hence, the Negative Ground of the external 10-30VDC source can be isolated from the Negative Ground of the Battery input to the inverter.

The inverter will switch ON when the external relay contact / switch is closed [External DC voltage (10-33VDC) is fed to terminals 3 and 4 of the Terminal Block (10, Fig 6.1a)]. The inverter will switch OFF when the external relay contact / switch is opened [External DC voltage (10-33VDC) is removed from terminals 3 and 4 of the Terminal Block (10, Fig 6.1a)].

- **1-Wire ON/OFF Control Using Switched DC Voltage from the Battery Supplying the Inverter, Fig 8.2(c) :**



### CAUTION!

1. Please ensure correct polarity of wiring connection. Positive (+) of the battery voltage should be connected to Terminal 3. In case the polarity is reversed, the ON/OFF control will NOT operate. The input to this terminal is protected against reverse polarity
2. Use 1A fuse as shown as close to the Battery input point as possible

The inverter will switch ON when the external relay contact / switch is closed [Voltage from the 12V / 24V battery supplying the inverter is fed to terminal 3 of the Terminal Block (10, Fig 6.1a)]. The inverter will switch OFF when the external relay contact / switch is opened [Voltage from the 12V / 24V battery supplying the inverter DC voltage is removed from terminal 3 of Terminal Block (10, Fig 6.1a)]. **In a vehicle / RV, the control voltage may be fed directly from the Ignition Switch. This will switch ON the inverter when the Ignition is ON and switch OFF the inverter when the Ignition is switched OFF.**

## SECTION 8 | Installation

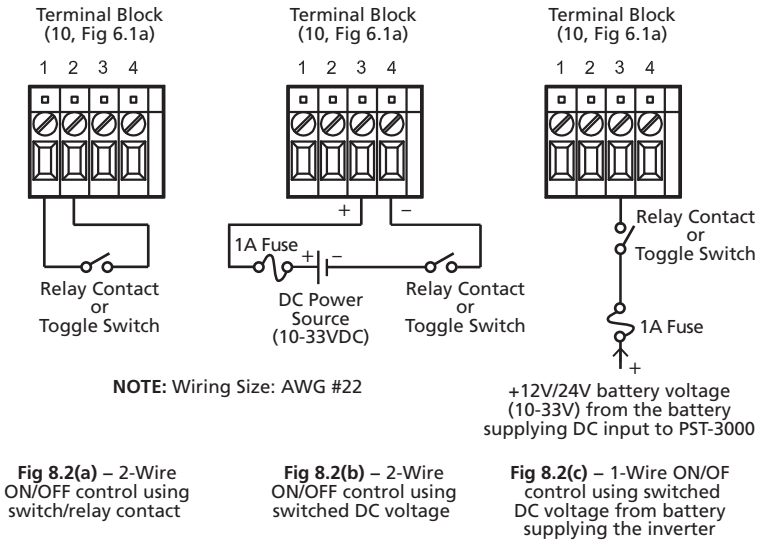

Fig. 8.2: ON/OFF Control from Remote Location using External 2-Wire or 1-Wire Control

## SECTION 9 | Operation

### 9.1 SWITCHING THE INVERTER ON/OFF

Before switching on the inverter, check that all the AC loads have been switched off. The 3-Position Rocker Switch marked ON/OFF/EXT. Switch (1, Fig 6.1a) on the front panel of the inverter is used to switch ON and switch OFF the inverter. This switch operates a low power control circuitry, which in turn controls all the high power circuitry.

The unit can also be switched ON/OFF remotely as follows:

- Through optional Remote Control Model RC-300 connected to Modular Jack RJ-50 (9, Fig 6.1a). Read Optional Remote Control Manual for RC-300 for details.
- Using 2-wire or 1-wire External Switching Control. See details under heading "ON/OFF Control from Remote location using 2-Wire or 1-Wire External ON/OFF Control" on page 38.



#### CAUTION!

Please note that the ON/OFF switch is not switching the high power battery input circuit. Parts of the DC side circuit will still be alive even when the switch is in the OFF position. Hence, disconnect the DC and AC sides before working on any circuits connected to the inverter.

## SECTION 9 | Operation



### ATTENTION!

Veillez noter que l'interrupteur ON/OFF ne gère pas le circuit d'entrée de batterie à haute puissance. Certaines parties du circuit de côté CC seraient encore actives même si l'onduleur a été fermé. Alors, il faut déconnecter tous les côtés CC et CA avant de travailler sur n'importe quel circuit connecté à l'onduleur.

When the inverter is switched ON, the Green LED marked "POWER" (2, Fig 6.1a) will be lighted. This LED indicates that the input section of the inverter is operating normally. Under normal operating conditions, AC output voltage will now be available at the GFCI Duplex Receptacle (6, Fig 6.1a) and at the AC output terminals for hardwiring (13, Fig 6.1b). The Green indicator light on the GFCI will be lighted.

Switch on the AC load(s). The Green LED marked "POWER" (2, Fig 6.1a) and the indication light on the GFCI should remain lighted for normal operation of the load.

### 9.2 POWERING ON THE LOADS

After the inverter is switched on, it takes a finite time to become ready to deliver full power. Hence, always switch on the load(s) after a few seconds of switching on the inverter. Avoid switching on the inverter with the load already switched on. This may prematurely trigger the overload protection.

When a load is switched on, it may require initial higher power surge to start. Hence, if multiple loads are being powered, they should be switched on one by one so that the inverter is not overloaded by the higher starting surge if all the loads are switched on at once.

### 9.3 TEMPERATURE CONTROLLED COOLING FAN

One thermostatically controlled cooling fan (18, Fig 6.1c) has been provided for forced air cooling. Temperature of a critical hot spot inside the inverter (Power Transformer T6) is monitored to activate the fan and the over temperature shut-down. When the temperature of this hot spot reaches  $55^{\circ}\text{C} \pm 3^{\circ}\text{C}$ , the fan is switched ON. The fan will be automatically switched OFF once the hot spot cools down to  $45^{\circ}\text{C} \pm 3^{\circ}\text{C}$ . Please note that the fan may not switch ON at low loads or if the ambient temperature is cooler. This is normal.

### 9.4 INDICATIONS FOR NORMAL OPERATION

When the inverter is operating normally and supplying AC load(s), the Green LED marked "POWER" (2, Fig 6.1a) and the Green indication light on the GFCI will be lighted. *Please see Section 10 "Protections" and Section 11 "Troubleshooting Guide" for symptoms of abnormal operation.*

## SECTION 9 | Operation

### 9.5 NO LOAD DRAW (IDLE CURRENT)

When the unit is switched ON, all the circuitry inside the inverter becomes alive and the AC output is made available. In this condition, even when no load is being supplied (or, if a load is connected but has been switched OFF), the inverter draws a small amount of current from the batteries to keep the circuitry alive and ready to deliver the required power on demand. This is called the "Idle Current" or the "No Load Draw". Hence, when the load is not required to be operated, turn OFF the inverter to prevent unnecessary current drain from the battery.



#### CAUTION!

When the inverter is switched OFF using the optional external Remote Control RC-300, there will be a very minor current drain of up to 3mA for the 12V version of the inverter and up to 5mA for the 24V version of the inverter. There will be **NO** drain from the battery when the inverter is switched OFF as follows:

- a) **When NOT using external 1-Wire or 2-Wire ON/OFF Control:** By switching OFF the 3-Position Rocker Switch (1, Fig 6.1a) to center position marked "ON" / "OFF"
- b) **When using external 1-Wire or 2-Wire ON/OFF Control:** By Switching OFF the inverter by (i) opening the switch or the relay contact in 2-Wire ON/OFF Control (Fig 8.2a) or (ii) opening the switch or relay contact in 2-Wire ON/OFF Control using switched DC voltage (Fig 8.2b) or (iii) opening the switch or relay contact in 1-Wire ON/OFF Control using switched DC voltage from the battery supplying the inverter.



#### ATTENTION!

Lorsque l'onduleur est éteint en utilisant la télécommande RC-300 en option, il y aura une consommation de courant très mineur jusqu'à 3 mA pour la version 12V de l'onduleur et jusqu'à 5 mA pour la version 24V de l'onduleur. Il n'y aura pas d'exode de la batterie lorsque l'onduleur est désactivé comme suit:

- a) **lorsque vous n'utilisez pas le contrôle ON/OFF du fil-1 et le fils-2 externe:** en éteignant l' interrupteur à 3 positions (1, Fig 6.1a ) pour centrer la position marquée "ON" / "OFF"
- b) **lorsque vous utilisez le contrôle ON/OFF du fil-1 et le fils-2 externe:** en éteignant l'onduleur par ( i ) en allumant l' interrupteur ou le contact du relais en Contrôle ON / OFF 2 -fils ( figure 8.2a ) ou ( ii ) en allumant l' interrupteur ou relais Contrôle ON / OFF 2 -fils en utilisant la tension CC ( figure 8.2 b ) ou ( iii ) en allumant l' interrupteur ou le contact de relais contrôle ON / OFF 1-fil en utilisant la tension CC de la batterie qui alimente l'onduleur .

## SECTION 10 | Protections

### 10. PROTECTIONS

The inverter has been provided with protections detailed below:

#### 10.1 POWER SURGE / OVERLOAD / SHORT CIRCUIT SHUT DOWN



##### INFO

Please refer to definitions of Active Power (Watts), Apparent Power (VA) and Power Factor (PF) at Section 2.1. In the explanation below, the values of Power are expressed in Apparent Power in VA. Corresponding Active Power (Watts, W) will depend upon the type of load (Resistive or Reactive) and its Power Factor (Power Factor may range from 1 to 0.5). Please note the following:

- Active Power (Watts) = Apparent Power (VA) x Power Factor (PF).
- For resistive type of loads, the Power Factor = 1 and hence, Apparent Power (VA) = Active Power (Watts, W)
- For reactive types of loads, the Power Factor will be  $< 1$  (up to 0.5) and hence, the Active Power (Watts, W) will be less than the Apparent Power (VA)

The AC output voltage will shut down due to overload and short circuit conditions as follows:

**Power Surge Condition:** When the AC output current tries to exceed around 200% of the rated value, output current limiting is carried out instantly resulting in drop in the AC output voltage (the drop is proportional to the load impedance). Surge Power of 200% will, thus, be provided for  $< 8$  ms every half cycle. If this situation continues for 2 to 2.5 sec Overload Condition is activated.

**Overload Condition:** If there is a continuous overload of 110% to 115% for 2 to 2.5 sec, the output voltage will be shut down. Red LED marked "OVERLOAD" (3, Fig 6.1a) will turn ON, the Green indication light on the GFCI outlet will be OFF and buzzer alarm will sound. The Green LED marked "POWER" (2, Fig 6.1a) will continue to be lighted. The unit will be latched in this shut down condition and will require manual reset. To reset, switch OFF the unit using the 3-Position Rocker Switch "ON/Off/EXT. Switch", wait for 3 minutes and then switch ON the unit again. Before switching ON, determine and remove the cause of overloading.

**Short Circuit Condition:** Short circuit condition will be detected when the AC output voltage drops to 80VAC or lower over a period of around 1 to 1.5 sec. The AC output voltage will be shut down thereafter.

Red LED marked "OVERLOAD" (3, Fig 6.1a) will turn ON, the Green indication light on the GFCI outlet will be OFF and buzzer alarm will sound. The Green LED marked "POWER" (2, Fig 6.1a) will continue to be lighted. The unit will be latched in this shut down condition and will require manual reset. To reset, switch OFF the unit using the 3-Position Rocker Switch "ON/Off/EXT. Switch", wait for 3 minutes and then switch ON the unit again. Before switching ON, determine and remove the cause of overloading.

## SECTION 10 | Protections

### 10.2 WARNING ALARM - LOW DC INPUT VOLTAGE

The voltage at the DC input terminals will be lower than the voltage at the battery terminals due to voltage drop in the battery wires and connectors. The drop in the voltage at the DC input terminals of the inverter could be due to lower battery voltage or due to abnormally high drop in the battery wires if the wires are not thick enough (*Please see Section 8.4.3 "Connection from Batteries to the DC Input Side-Sizing of Cables and Fuses"*). If the voltage at the DC input terminals drops to  $10.7V \pm 0.1V$  or lower for PST-3000-12 or, to  $21.4V \pm 0.2V$  or lower for PST-3000-24, a buzzer alarm will be sounded. The Green LED marked "POWER" (2, Fig 6.1a) and indication light on the GFCI will continue to be lighted and the AC output voltage would continue to be available. This warning buzzer alarm indicates that the battery is running low and that the inverter will be shut down after sometime if the voltage at the inverter terminals further drops to  $10V \pm 0.1V$  or lower for PST-3000-12 or  $20V \pm 0.2V$  or lower for PST-3000-24.

### 10.3 LOW DC INPUT VOLTAGE SHUT DOWN

If the voltage at the DC input terminals drops to  $10V \pm 0.1V$  or lower for PST-3000-12 or  $20V \pm 0.2V$  or lower for PST-3000-24, the AC output is shut down. Buzzer alarm is sounded. The Green LED marked "POWER" (2, Fig 6.1a) will remain lighted. The Green indication light on the GFCI will be OFF.

The unit will reset automatically when the DC input voltage rises to  $11.5V \pm 0.3V$  or higher for PST-3000-12 or to  $23V \pm 0.5V$  or higher for PST-3000-24.

### 10.4 HIGH DC INPUT VOLTAGE SHUTDOWN

If the voltage at the DC input terminals rises to 16.5V or higher for PST-3000-12 or, to 33V or higher for PST-3000-24, the AC output voltage will be shut down temporarily. Buzzer alarm will be sounded. The Green LED marked "POWER" (2, Fig 6.1a) will remain lighted. The Green indicator light on the GFCI will be OFF. The unit will be reset automatically when the voltage drops down to  $< 16.5V$  for PST-3000-12 or to  $< 33V$  for PST-3000-24.

### 10.5 OVER-TEMPERATURE SHUT DOWN

In case of failure of the cooling fans or in the case of inadequate heat removal due to higher ambient temperatures / insufficient air exchange, the temperature inside the unit will increase. The temperature of a critical hot spot inside the inverter is monitored (Power Transformer T3), and at  $90^{\circ}C \pm 5^{\circ}C$ , the AC output of the inverter is shut down temporarily. Buzzer alarm will be sounded. The Green LED marked "POWER" (2, Fig 6.1a) will remain lighted. The Green indication light on the GFCI will be OFF.

The unit will automatically reset after the hot spot has cooled down to  $65^{\circ}C \pm 5^{\circ}C$ .



## SECTION 10 | Protections

### 10.6 GROUND FAULT / LEAKAGE PROTECTION FOR AC OUTPUT THROUGH NEMA5-20R GFCI DUPLEX RECEPTACLE

AC output is supplied through hardwiring connections (11, Fig 6.1b) or through NEMA5-20R GFCI Duplex Receptacle (6, Fig 6.1a). The GFCI will trip if there is 5 to 6 mA leakage / Ground fault on the load side, or if Neutral and Ground are bonded on the load side. When tripped, the Green LED indication will be switched off. Remove the cause of tripping. Switch ON the inverter if OFF and then, press the "Reset Button" on the GFCI to reset (GFCI will not reset if the inverter is OFF and there is no AC voltage on the line side of the GFCI).



#### CAUTION!

Please note that the NEMA5-20R GFCI Duplex Receptacle (6, Fig 6.1a) is a Ground Fault and Leakage Protection Device and NOT an Over Current Protection Device (Breaker). The current carrying capacity of each of the two receptacles is 20A intermittent and 16A continuous. As the maximum continuous AC output current of PST-3000 is 25A, please ensure that the full 25A output is NOT drawn from only one receptacle but is shared between the two receptacles so that the above current carrying capacity of each of the receptacles is not exceeded. If the full rated current of 25A is drawn from only one receptacle, the receptacle / GFCI will be damaged. Another option for drawing the full rated AC output current of 25A is to use hardwiring connection (11, Fig 6.1b)



#### ATTENTION!

Veillez noter que la NEMA5-20R Le GFCI Récipient Duplex (6, Fig. 6.1a) est un défaut à la terre et dispositif de protection de fuite et pas un dispositif de protection contre les surintensités (disjoncteur). La capacité de transport du courant de chacune des deux récipients est 20A : intermittent et 16A continu. Comme le courant de sortie CA maximale continue de la PST-3000 est 25A, veuillez vous assurer que la pleine sortie 25A n'est pas tirée d'un seul réceptacle mais est partagée entre les deux réceptacles de sorte que la capacité de transport de courant au-dessus de chacun des récipients n'est pas dépassé. Si la totalité du courant nominal de 25A est tirée d'un seul réceptacle, le récipient / GFCI sera endommagé. Une autre option pour le dessin du courant de sortie alternative nominale complète de 25A est à utiliser hardwiring connection (11, Fig. 6.1b)

## SECTION 10 | Protections

### 10.7 INTERNAL DC SIDE FUSES

The following DC side fuses have been provided for internal protection of the DC input side. The fuses are 32V, Automotive Type Blade Fuses, Type "ATO" by Littell Fuse or equivalent:

PST-3000-12: 12 pieces of 30A in parallel = 360A total

PST-3000-24: 12 pieces of 15A in parallel = 180A total

**NOTE:** Fuses are soldered to the PCB.

### 10.8 REVERSE POLARITY AT THE DC INPUT TERMINALS

The Positive of the battery should be connected to the Positive DC input terminal of the inverter and the Negative of the battery should be connected to the Negative DC input terminal of the inverter. A reversal of polarity (the Positive of the battery wrongly connected to the Negative DC input terminal of the inverter and the Negative of the battery wrongly connected to the Positive DC input terminal of the inverter) will blow the external / internal DC side fuses. If the DC side fuse is blown, the inverter will be dead. The Green LED marked "POWER" (2, Fig 6.1a) and the Green indication light on the GFCI will be switched OFF and there will be no AC output.



#### INFO

Reverse polarity connection is likely to damage the DC input circuitry. The internal fuse(s) should be replaced with the same size of fuse(s) used in the unit. If the unit does not work after replacing the fuse(s), it has been permanently damaged and will require repair / replacement (*Please read Section 11 - "Troubleshooting Guide" for more details*).



#### CAUTION!

Damage caused by reverse polarity is not covered by warranty! When making battery connections on the input side, make sure that the polarity of battery connections is correct (Connect the Positive of the battery to the Positive terminal of the unit and the Negative of the battery to the Negative terminal of the unit). If the input is connected in reverse polarity, DC fuse(s) inside the inverter / external fuse will blow and may also cause permanent damage to the inverter.



#### ATTENTION!

Des dommages causés par un inversement de polarités ne sont pas couverts par la garantie! Quand vous faites des connexions à la batterie du côté d'entrée, veuillez assurer que les polarités sont mises du bon côté (Lié le Positif de la batterie à la borne Positive de l'appareil et le Négatif de la batterie à la borne Négative de l'appareil). Si les polarités de l'entrée sont mises à l'envers, le fusible CC externe du côté d'entrée va s'exploser et pourrait causer des dommages permanents à l'onduleur.

## SECTION 11 | Troubleshooting Guide

ISSUE	POSSIBLE CAUSE	REMEDY
<p>When switched ON, the Green LED marked "POWER" (2, Fig 6.1a) does not light. Buzzer is OFF. There is no AC output voltage. Green indication light on the GFCI is OFF.</p>	<p>There is no voltage at the DC input terminals</p>	<ul style="list-style-type: none"> <li>• Check the continuity of the battery input circuit.</li> <li>• Check that the internal/external battery fuses are intact. Replace if blown.</li> <li>• Check that all connections in the battery input circuit are tight.</li> </ul>
	<p>Polarity of the DC input voltage has been reversed that has blown the external / internal DC side fuses (<b>Note: Reverse polarity may cause permanent damage.</b> Damage caused due to reverse polarity is not covered by warranty)</p>	<ul style="list-style-type: none"> <li>• Check external and internal fuses. Internal fuses may be soldered and may not be easily replaceable. Replace fuses. If unit does not work, call Technical Support for repair.</li> </ul>
<p>Low AC output voltage (No buzzer alarm).</p>	<ul style="list-style-type: none"> <li>• AC load is exceeding 200% Surge Overload</li> <li>• Load is approaching 200% Surge Overload during lower DC input voltage</li> </ul>	<ul style="list-style-type: none"> <li>• Check that the battery is fully charged. Recharge, if low.</li> <li>• Check that the battery cables are thick enough to carry the required current over the required length. Use thicker cables, if required.</li> <li>• Tighten connections of battery input circuit.</li> <li>• Reduce load.</li> </ul>
<p>AC output voltage is available. Buzzer alarm is sounded at no load when load is switched ON. The Green LED marked "POWER" (2, Fig 6.1a) is lighted. Indication light on the GFCI is Green.</p>	<ul style="list-style-type: none"> <li>• Low DC input voltage alarm</li> <li>• DC input voltage is 10.7V or lower but &gt; 10V <math>\pm</math> 0.1V for PST-3000-12</li> <li>• DC input voltage is 21.4V <math>\pm</math> 0.2V or lower but &gt; 20V <math>\pm</math> 0.2V for PST-3000-24</li> </ul>	<ul style="list-style-type: none"> <li>• Check that the battery is fully charged. Recharge, if low.</li> <li>• Check that the battery cables are thick enough to carry the required current over the required length. Use thicker cables, if required.</li> <li>• Tighten connections of the battery input circuit.</li> </ul>
<p>There is no AC output voltage. Buzzer alarm is sounded at no load or when load is switched ON. The Green LED marked "POWER" (2, Fig 6.1) is lighted. GREEN indication light on the GFCI is OFF.</p>	<ul style="list-style-type: none"> <li>• AC output voltage has been shut down due to low DC input voltage</li> <li>• DC input voltage is 10V <math>\pm</math> 0.1V or lower for PST-3000-12</li> <li>• DC input voltage is 20V <math>\pm</math> 0.2V or lower for PST-3000-24</li> </ul>	<ul style="list-style-type: none"> <li>• Check that the battery is fully charged. Recharge, if low.</li> <li>• Check that the battery cables are thick enough to carry the required current over the required length. Use thicker cables, if required.</li> <li>• Tighten connections of the battery input circuit.</li> <li>• The AC output voltage will switch ON automatically when the DC input voltage rises to 11.5V <math>\pm</math> 0.1V or higher for PST-3000-12 or 23V <math>\pm</math> 0.2V or higher for PST-3000-24.</li> </ul>

## SECTION 11 | Troubleshooting Guide

ISSUE	POSSIBLE CAUSE	REMEDY
<p>There is no AC output. The Green LED marked "POWER" (2, FIG 6.1A) is lighted. Buzzer is ON. Green indication light on the GFCI is OFF.</p>	<p>Shut-down due to high input DC voltage – 16.5V or higher for PST-3000-12 and 33V or higher for PST-3000-24.</p>	<ul style="list-style-type: none"> <li>• Check that the voltage at the DC input terminals is less than 16.5V for PST-3000-12 and less than 33V for PST-3000-24.</li> <li>• Ensure that the maximum charging voltage of the battery charger / alternator / solar charge controller is below 16.5V for PST-3000-12 and below 33V for PST-3000-24.</li> <li>• Ensure that an unregulated solar panel is not used to charge a battery. Under cold ambient temperatures, the output of the solar panels may exceed 22V for 12V Panels or 42V for 24V Panels. Ensure that a charge controller is used between the solar panel and the battery.</li> <li>• Automatic Reset when voltage drops to &lt; 16.5V for PST-3000-12 or &lt; 33V for PST-3000-24</li> </ul>
<p>AC output shuts down completely. Red LED marked "OVERLOAD" (3, Fig 6.1a) is lighted. Buzzer is ON. The Green LED marked "POWER" (2, Fig 6.1a) is lighted. Green indication light on the GFCI is OFF.</p>	<p>Permanent shut-down of the AC output due to continuous overload &gt; 110% to 115% for 2 to 2.5 sec or due to short circuit on the AC load circuit (AC output voltage is 80VAC or lower for 1 to 1.5 sec).</p>	<ul style="list-style-type: none"> <li>• Reduce the load / remove the short circuit</li> <li>• The load is not suitable as it requires higher power to operate. Use an inverter with higher power rating.</li> <li>• If the unit goes into permanent overload again after resetting and removing the load completely, the unit has become defective. Call Technical support.</li> </ul> <p><b>NOTE:</b> The unit will be latched in this shut-down condition and will require manual reset. To reset, switch OFF the power ON/OFF switch (1, Fig 6.1), wait for 3 minutes and then switch ON again.</p> <p>Before switching on again, remove the cause of the shut-down.</p>
<p>There is no AC output. Buzzer alarm is sounded. Red LED marked "OVER TEMP" (4, Fig 6.1a) is lighted. The Green LED marked "POWER" (2, Fig 6.1a) is lighted. Green indication light on the GFCI is OFF.</p>	<p>Shut-down due to over temperature because of fan failure or inadequate cooling as a result of high ambient temperature or insufficient air exchange</p>	<p>Check that the fans are working. If not, the fan control circuit may be defective. Call Technical Support.</p> <p>If the fans are working, check that the ventilation slots on the suction side and the openings on the discharge side of the fans are not obstructed.</p> <p>If the fans are working and the openings are not obstructed, check that enough cool replacement air is available. Also check that the ambient air temperature is less than 40°C.</p> <p>Reduce the load to reduce the heating effect.</p> <p>After the cause of overheating is removed and the unit cools down sufficiently, it will reset automatically.</p>
<p>There is no AC output. Green indication on the GFCI is OFF. The Green LED marked "POWER" (2, Fig 6.1a) is lighted. No buzzer alarm.</p>	<p>GFCI has tripped due to leakage or due to Neutral to Ground bond on the load side.</p>	<p>Check load side circuits for leakage or Neutral to Ground bonding and correct. Press "Reset Button" on the GFCI to reset. Ensure that the inverter is ON before re-setting the GFCI.</p>

## SECTION 12 | Specifications

MODEL NO.	PST-3000-12	PST-3000-24
<b>OUTPUT</b>		
OUTPUT VOLTAGE	120 VAC $\pm$ 3%	120 VAC $\pm$ 3%
MAXIMUM OUTPUT CURRENT	25A	25A
OUTPUT FREQUENCY	60 Hz $\pm$ 1%	60 Hz $\pm$ 1%
TYPE OF OUTPUT WAVEFORM	Pure Sine Wave	Pure Sine Wave
TOTAL HARMONIC DISTORTION OF OUTPUT WAVEFORM	< 3%	< 3%
CONTINUOUS OUTPUT POWER (At Power Factor = 1)	3000 Watts	3000 Watts
SURGE OUTPUT POWER	6000 Watts (< 8 ms)	6000 Watts (< 8 ms)
PEAK EFFICIENCY	> 85%	> 88%
AC OUTPUT CONNECTIONS	NEMA5-20R GFCI Duplex Outlets, Terminal Block for hard-wiring	NEMA5-20R GFCI Duplex Outlets, Terminal Block for hard-wiring
<b>INPUT</b>		
NOMINAL DC INPUT VOLTAGE	12V	24V
DC INPUT VOLTAGE RANGE	10.7 - 16.5 VDC	21.4 - 33 VDC
MAXIMUM INPUT CURRENT	360A	180A
DC INPUT CURRENT AT NO LOAD	< 1.6A	< 1.0A
DC INPUT CONNECTIONS	Bolt & Nut: 5/16" x 18 TPI	Bolt & Nut: 5/16" x 18 TPI
DC INPUT FUSES (INTERNAL)	12 X 30A = 360A (Each Type ATC, 32V, 30A)	12 x 15A = 180A (Each Type ATC, 32V, 15A)
<b>DISPLAY</b>		
LED	Power, Overload, Over Temperature	Power, Overload, Over Temperature
<b>PROTECTIONS</b>		
LOW DC INPUT VOLTAGE ALARM	10.7V $\pm$ 0.1V	21.4V $\pm$ 0.2V
LOW DC INPUT VOLTAGE SHUTDOWN	10V $\pm$ 0.1V; Auto-reset: 11.5V $\pm$ 0.3V	20V $\pm$ 0.2V; Auto-reset: 23V $\pm$ 0.5V
HIGH DC INPUT VOLTAGE SHUTDOWN	16.5V; Auto-reset: < 16.5V	33V; Auto-reset: < 33V
SHORT CIRCUIT SHUTDOWN	When output voltage drops to 80VAC or lower for 1 to 1.5 sec	
OVERLOAD SHUTDOWN	At overload of 110% to 115% for 2 to 2.5 sec	
GROUND FAULT SHUTDOWN	Only on GFCI outlets (5 to 6 mA leakage)	
OVER TEMPERATURE SHUTDOWN	90°C $\pm$ 5°C (Sensed at Transformer T3); Auto reset at 65°C $\pm$ 5°C	
REVERSE POLARITY ON DC INPUT SIDE	External / internal DC sides fuses will blow	
<b>REMOTE CONTROL</b>		
WIRED REMOTE CONTROL WITH LED / LED DISPLAY	RC-300 (sold separately) with 25' cable	
WIRED ON / OFF CONTROL	(i) By switching external contact (ii) By switching external 12V/24V signal	
<b>COOLING</b>		
FORCED AIR COOLING	Temperature controlled fan (Sensed at Transformer T6) Fan ON at 55°C $\pm$ 3°C; Fan OFF at 45°C $\pm$ 3°C	
<b>COMPLIANCE</b>		
SAFETY	Intertek - ETL Listed. Conforms to ANSI/UL Standard 458 and certified to CSA STD C22.2 No. 107.1-01	
EMI / EMC	FCC Part 15(B), Class A	
<b>ENVIRONMENT</b>		
WORKING ENVIRONMENT	Indoor use	
OPERATING TEMPERATURE RANGE	-20 to 40°C / -4 to 104°F	
STORAGE TEMPERATURE	-30 to 70°C / -22 to 158°F	
RELATIVE HUMIDITY	90%, non condensing	
<b>DIMENSIONS</b>		
(W X D X H), MM	263 x 456.5 x 145	263 x 456.5 x 145
(W X D X H), INCHES	10.35 x 17.97 x 5.71	10.35 x 17.97 x 5.71
<b>WEIGHT</b>		
KG	9.8	9.8
LBS	21.6	21.6

### NOTES:

1. All power ratings are specified for resistive load at Power Factor = 1.
2. All specifications given above are at ambient temperature of 25°C / 77°F.
3. Specifications are subject to change without notice

## SECTION 12 | Specifications



### CAUTION! RISK OF FIRE

Do not replace any vehicle fuse with a rating higher than recommended by the vehicle manufacturer. PST-3000-12 is rated to draw 360 Amperes from 12V vehicle outlet and PST-3000-24 is rated to draw 180 Amperes from 24V battery vehicle outlet. Ensure that the electrical system in your vehicle can supply this unit without causing the vehicle fusing to open. This can be determined by making sure that the fuse in the vehicle, which protects the outlet, is rated higher than 360 Amperes for PST-3000-12 (12V battery), or higher than 180 Amperes for PST-3000-24 (24V battery). Information on the vehicle fuse ratings is typically found in the vehicle operator's manual. If a vehicle fuse opens repeatedly, do not keep on replacing it. The cause of the overload must be found. On no account should fuses be patched up with tin foil or wire as this may cause serious damage elsewhere in the electrical circuit or cause fire.



### ATTENTION! RISQUE D'INCENDIE!

Ne remplacez pas un fusible de véhicule avec une taille plus grande que celle qui est recommandée par le fabricant du véhicule. Ce produit est fabriqué pour tirer 360 Ampères d'une prise de véhicule de 12V et 180 Ampères d'une prise de 24V. Donc, il faut s'assurer que le système électrique dans le véhicule puisse alimenter l'onduleur sans que le fusible s'ouvre. Vérifiez, en lisant le manuel du véhicule, que le fusible qui protège la prise (du véhicule) est fabriqué pour plus que 360 Amp (batterie de 12V) ou, plus que 180 Amps (Batterie de 24V). Si le fusible s'ouvre plusieurs fois, ne continuez pas de le remplacer. Dans ce cas, il faut trouver la cause de la surcharge. Il faut jamais essayer de réparer/comblé un fusible avec un fil ou papier aluminium, ça pourrait engendrer des dommages dans le circuit électrique ou même causer un incendie.

## SECTION 13 | Warranty

### 2 YEAR LIMITED WARRANTY

The PST-3000-12 and PST-3000-24 are manufactured by Samlex America, Inc. (the “Warrantor”) is warranted to be free from defects in workmanship and materials under normal use and service. The warranty period is 2 years for the United States and Canada, and is in effect from the date of purchase by the user (the “Purchaser”).

Warranty outside of the United States and Canada is limited to 6 months. For a warranty claim, the Purchaser should contact the place of purchase to obtain a Return Authorization Number.

The defective part or unit should be returned at the Purchaser’s expense to the authorized location. A written statement describing the nature of the defect, the date of purchase, the place of purchase, and the Purchaser’s name, address and telephone number should also be included.

If upon the Warrantor’s examination, the defect proves to be the result of defective material or workmanship, the equipment will be repaired or replaced at the Warrantor’s option without charge, and returned to the Purchaser at the Warrantor’s expense. (Contiguous US and Canada only)

No refund of the purchase price will be granted to the Purchaser, unless the Warrantor is unable to remedy the defect after having a reasonable number of opportunities to do so. Warranty service shall be performed only by the Warrantor. Any attempt to remedy the defect by anyone other than the Warrantor shall render this warranty void. There shall be no warranty for defects or damages caused by faulty installation or hook-up, abuse or misuse of the equipment including exposure to excessive heat, salt or fresh water spray, or water immersion.

No other express warranty is hereby given and there are no warranties which extend beyond those described herein. This warranty is expressly in lieu of any other expressed or implied warranties, including any implied warranty of merchantability, fitness for the ordinary purposes for which such goods are used, or fitness for a particular purpose, or any other obligations on the part of the Warrantor or its employees and representatives.

There shall be no responsibility or liability whatsoever on the part of the Warrantor or its employees and representatives for injury to any persons, or damage to person or persons, or damage to property, or loss of income or profit, or any other consequential or resulting damage which may be claimed to have been incurred through the use or sale of the equipment, including any possible failure of malfunction of the equipment, or part thereof. The Warrantor assumes no liability for incidental or consequential damages of any kind.

**Samlex America Inc. (the “Warrantor”)**

**[www.samlexamerica.com](http://www.samlexamerica.com)**

# Contact Information

Toll Free Numbers

Ph: 1 800 561 5885

Fax: 1 888 814 5210

Local Numbers

Ph: 604 525 3836

Fax: 604 525 5221

Website

[www.samlexamerica.com](http://www.samlexamerica.com)

USA Shipping Warehouses

Kent, WA

Plymouth, MI

Canadian Shipping Warehouse

Delta, BC

Email purchase orders to

[orders@samlexamerica.com](mailto:orders@samlexamerica.com)



**samlex**america®



## APPENDIX A



**samlex**power®

**Onduleur de  
Puissance  
CC-CA**  
Onde  
Sinusoïdale Pure

PST-3000-12  
PST-3000-24

**SECTION 8  
Installation**

Veillez lire  
les instructions  
trouvées dans  
ce manuel  
avant d'installer  
votre onduleur.

**MISE EN GARDE!**

1. Avant de commencer l'installation, veuillez lire les instructions de sécurité expliquées dans la section 1 intitulée " Instructions de sécurité ".
2. On recommande que l'installation soit faite par un(e) électricien(ne) certifié(e).
3. Il y a plusieurs consignes trouvées dans ce guide qui ne sont pas toujours applicables si une norme nationale ou locale en prend place, concernant par exemple l'endroit d'installation ou à l'usage de l'appareil. Quelques exemples sont écrites ci-dessous.

**8.1 LIEU D'INSTALLATION**

Veuillez assurer que vous suivez les consignes suivantes:

**Environnement de travail :** utilisation en intérieur.

**Fraîcheur:** La chaleur est néfaste pour l'équipement électronique. Donc, veuillez assurer que l'unité est installée dans un endroit frais qui est à l'abri de la lumière directe du soleil et, est éloignée des autres dispositifs qui produisent de la chaleur.

**Bien aéré:** L'unité est refroidie par la convection et l'air refroidi grâce à des ventilateurs à température contrôlée. Les ventilateurs aspirent l'air frais en avant et en dessous (5, Fig 6.1a) et, expulsent l'air chaud par un échappement près des ventilateurs (18, Fig 6.1c). Pour éviter une fermeture de l'onduleur à cause d'un surchauffe, ne couvrez pas ces ouvertures ni installez l'unité quelque par où la circulation d'air est limitée. Gardez 25cm d'espace libre (dans tous les sens) autour de l'unité afin d'avoir une aération suffisante. Si elle est installée dans un enclos, des ouvertures doit être fournie pour ne pas bloquer l'admission d'air ni l'échappement de l'onduleur.

**Sec:** Il faut que l'unité soit à l'abri de l'eau, de la condensation ou n'importe quelle liquide qui pourrait la pénétrer ou tomber dessus.

**Propre:** L'endroit doit être à l'abri de la poussière et de la fumée. Assurez qu'il y aucune présence d'insectes ou de rongeurs. Ils pourraient entrer dans l'unité et bloquer les ouvertures de ventilation ou court-circuiter les circuits internes.

**Protection contre risque d'incendie:** L'unité n'a pas de protection ignifuge et devrait pas être placée là où se trouve des liquides inflammables comme l'essence, le propane ou, près d'un compartiment contenant des moteurs alimenté par essence. Gardez pas des matériaux inflammables/combustibles (papier, tissu, plastique, etc.) qui serait enflammés par la chaleur, des étincelles ou flammes.

**Proximité à la banque de batterie:** Mettez l'unité au plus près possible afin de prévenir une chute de tension excessive dans les câbles de batterie causerant une perte de puissance et un moindre rendement. Pourtant, il faut pas l'installez dans le même compartiment que les batteries (inondées, cellule mouillée) ni la montez quelque

part à l'exposition de vapeurs acides corrosives ou, de gaz inflammable (l'Oxygène et l'Hydrogène sont produits lorsque des batteries sont rechargées). Ces vapeurs pourront corroder et endommager l'unité et les gaz, s'il sont pas ventilés vont accumuler, et pourraient s'enflammer ou s'exploser.

**Accessibilité:** Ne bloquez pas le panneau frontal. Aussi, gardez les réceptacles CA et les connexions/bornes de câblage CC bien dégagées, car il va falloir les inspecter ou les servir de temps en temps.

**Prévention de l'Interférence de Fréquence Radio (IFR):** Cette unité se sert des circuits de commutation à haute puissance qui génèrent de l'IFR. Ceci est limité en fonction des normes requises. Situez des équipements électroniques susceptibles à IFR au plus loin possible de l'onduleur. *Pour en savoir plus, lisez la Section 3 «Réduction d'Interférence Électro Magnétique (IEM)».*

**8.2 DIMENSIONS GÉNÉRALES**

Les dimensions et la localisation des rainures de montage sont montrées dans la Figure 8.1.

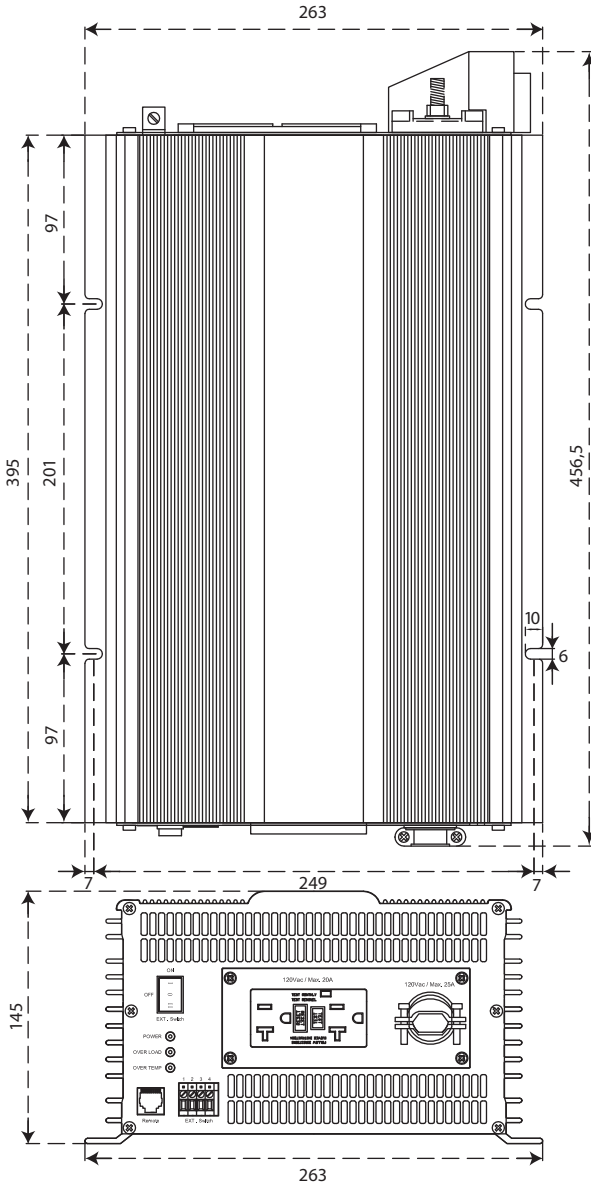

**NOTE:** Dimensions en mm

*La Fig. 8.1: Dimensions Générales et Rainures de Montage de PST-3000*

### 8.3 ORIENTATION DE MONTAGE

L'unité est équipée avec des admissions d'air et des échappement pour le ventilateur de refroidissement. Il faut que ça soit monté dans une manière appropriée afin d'assurer que des objets ne puissent pas tomber dans ces ouvertures, provoquant des dégâts électriques/mécaniques. Prenez- en compte aussi qu'elle devrait pas être montée au-dessus d'une matérielle combustible parce que les composants internes pourraient fondre et tomber de l'unité au-cas où il y un échec catastrophique, engendrant une risque d'incendie. La grosseur des ouvertures est limitée par rapport aux normes de sécurités pour empêcher ces risques quand l'unité est montée dans la façon propre. Le montage doit satisfaire aux exigences suivantes:

- Montez-la sur une surface non-inflammable.
- La surface doit pouvoir supporter les poids de l'unité.
- Montez-la horizontalement par-dessus une surface horizontale - qui repose sur une surface horizontale (p.e. sur une table ou étagère). Ou,
- Montez-la horizontalement sur une surface verticale (un mur par exemple) - mais c'est impératif que l'axe du ventilateur soit à l'horizontale (ventilateur à droite ou à gauche).



#### MISE EN GARDE!

Monter l'unité verticalement sur une surface verticale EST INTERDIT (c.a.d. que les ouvertures sont mise sur l'axe vertical). Comme c'est expliqué au-dessus, c'est pour empêcher une chute d'objet dans les ouvertures de ventilateurs (lorsqu'elles sont au-dessus) ou que des composants endommagé tombent par terre (lorsqu'elles sont en-bas).

La surface de l'unité serait probablement très chaude, surtout sous des charges plus exigeantes et/ou à des températures ambiantes plus chaudes. Alors, installez l'unité dans une façon qui limite l'accessibilité/ le contact de gens.

### 8.4 CONNEXIONS DE CÔTÉ CC

#### 8.4.1 Prévention d'une Surtension de l'Entrée CC

Il faut assurer que la tension d'entrée CC de cet appareil n'excède pas 16,5 VCC pour le système de batterie de 12V ou, 33,0 VCC pour le système de batterie de 24V pour empêcher des dégâts permanents à l'appareil. Veuillez suivre les consignes suivantes:

- Assurer que la tension de chargement maximale du chargeur de batterie externe / alternateur / contrôleur de charge n'excède pas une tension de 16,5 VCC (version 12V) ou, 33,0 VCC (version 24V).
- N'utilisez pas un panneau solaire non-réglé pour recharger une batterie connectée à cet appareil. En-dessous des températures froides ambiantes, la sortie du panneau pourrait atteindre > 22 VCC pour la version de 12 V ou, > 44 VCC pour la version de 24 V. Utilisez toujours un contrôleur de charge entre la batterie et le panneau solaire.
- Lorsque vous utilisez le mode«Diversion de Charge Contrôlée» pour un contrôleur de charge, la source solaire / éolienne / hydro-électrique est directement branchée à la banque de batteries. Dans ce cas, le contrôleur de charge va diriger le surplus de cou-

rant à une charge externe. Pendant le chargement de la batterie, le rapport cyclique à diversion augmentera. Dès que la batterie est complètement chargée, toute l'énergie de la source serait renvoyée vers la charge de diversion s'il n'y a plus d'autres charges. Le contrôleur de charge va déconnecter la charge de diversion si le courant nominale du contrôleur de charge est excédé. Une déconnexion de la charge de diversion pourrait potentiellement endommager la batterie et l'onduleur, ou les autres charges CC connectée à la batterie, à cause de la production de fortes tensions pendant les conditions de vents forts (générateurs éoliennes) ou flux d'eau rapide (générateurs hydro-électriques). Donc, il faut choisir une charge appropriée afin empêcher des conditions de surtension.

- Ne connectez pas l'appareil à un système de batterie avec une tension plus forte que la tension d'entrée de l'appareil (par exemple, connectez pas la version 12V à une batterie de 24V ou, la version 24V à une batterie de 48V).

#### 8.4.2. Prévenir la polarité inversée sur le côté d'entrée CC



##### ATTENTION!

Des dommages causés par un inversement des polarités ne sont pas couverts par la garantie! Quand vous faites des connexions à la batterie du côté d'entrée, veuillez assurer que les polarités sont mises du bon côté (Liez le Positif de la batterie à la borne Positive de l'appareil et le Négatif de la batterie à la borne Négative de l'appareil). Si les polarités de l'entrée sont mises à l'envers, le(s) fusible(s) CC dans l'onduleur va/vont s'exploser et pourrait causer des dommages permanents à l'onduleur.

#### 8.4.3 La Connexion de Batteries au Côté d'Entrée CC de l'Appareil – Tailles de Câbles et Fusibles Externes



##### ATTENTION!

La section d'entrée de l'onduleur a des condensateurs de grande valeur qui sont connectés aux bornes d'entrée. Tant que le boucle de connexion d'entrée CC (la borne (+) de la batterie ► le fusible externe ► la borne d'entrée positive de EVO ► la borne d'entrée négative de EVO ► la borne (-) de la batterie) est complet, ces condensateurs se mètreront en charge et l'unité tira momentanément un courant très lourd pour charger ces condensateurs qui produiront des étincelles sur le dernier contact de la boucle d'entrée, même lorsque l'appareil est en état de tension. Assurez que le fusible externe est insérer seulement après que toutes les connexions sont faites dans le boucle pour que des étincelles se produisent seulement à l'endroit du fusible.

Flux du courant dans un conducteur est opposé par la résistance du conducteur. La résistance du conducteur est directement proportionnelle à la longueur du conducteur et inversement proportionnelle à son diamètre (l'épaisseur). La résistance dans un conducteur produit des effets indésirables comme la perte de tension et la surchauffe. La taille (l'épaisseur) des conducteurs est classée par l' AWG (American Wire Guage). Les

conducteurs plus épais que l'AWG # 4/0 sont dimensionnés en MCM / kcmil . Tableau 8.1 ci-dessous donne Résistance en Ohm (  $\Omega$  ) par pied à 25 ° C / 77 ° F pour le dimensionnement de fil recommandé pour une utilisation avec cet onduleur.

TAILLE DE FILS, AWG	RÉSISTANCE EN OHM PAR PIED A 25°C / 77°F
AWG#2	0,000159 $\Omega$ par pied
AWG#1/0	0,000096 $\Omega$ par pied
AWG#2/0	0,000077 $\Omega$ par pied
AWG#4/0	0,000050 $\Omega$ par pied

Les conducteurs sont protégés d'un matériau isolant cotés pour température spécifique par ex. 105 °C/221 °F. Comme le flux de courant génère de la chaleur qui affecte l'isolement, il y a une valeur maximale admissible de courant (appelé "Courant admissible ") pour chaque taille de conducteur en fonction de la température nominale de son isolement. L'isolant des câbles seront également touchés par l'élévation de la température d'exploitation des terminaux à laquelle elles sont connectées. L'intensité admissible des câbles est basé sur UL-458 et le Code électrique national (NEC)-2014. Veuillez voir les détails donnés dans la rubrique "Notes du tableau 8.2".

Le circuit d'entrée CC doit subir à des courants CC forts et ainsi, il faut que la taille des câbles et des connecteurs est sélectionnée pour réduire la perte de tension entre la batterie et l'onduleur. Avec des câbles moins épais et des connexions lâches la performance de l'onduleur est diminuée et en plus, ça pourrait produire une réchauffement anormale qui risque de fondre l'isolation ou commencer un incendie. Normalement, l'épaisseur du câble doit être telle que la chute de tension due au courant et la résistance de la longueur du câble doit être inférieure à 2 % à 5 %. Utilisez des câbles en cuivre multi-brin résistant à qui sont classés au moins à 105°C / 77°F. N'utilisez pas des câbles en aluminium car ils ont une résistance plus haute (par la longueur de l'unité). On peut acheter des câbles aux magasins de fournitures pour marin/soudage. Effets de basse tension sur les charges électriques communs sont donnés ci-dessous :

- **Circuits d'allumage** - Incandescent et Halogène Quartz: Une perte de tension à 5% causera une perte de 10% de la lumière émise. Cet effet est grâce à deux choses, non seulement l'ampoule reçoive moins de puissance mais, aussi le filament refroidi change de la chaleur-blanc à la chaleur-ROUGE, qui émet moins de lumière visible.
- **Circuits d'allumage** - Fluorescent: La perte de tension est presque proportionnelle à la perte de lumière émise.
- **Moteurs à Induction CA** - Souvent, Ils font partie des outils électriques, des dispositifs, pompe à puits, etc. Au démarrage, ils exigent une surcharge de puissance. Si la tension baisse trop, ils pourraient pas marcher et même seront endommagés.
- **Circuits de rechargement d'une batterie PV** - La perte de tension pourrait causer une perte de puissance disproportionnée. Par exemple, une perte de tension à 5% peut réduire le courant de charge par une pourcentage beaucoup plus grande que 5%.

### 8.4.4 Protection de Fusible dans le Circuit de Batterie

Une batterie est une source illimitée de courant. Lors de court-circuits, une batterie pourrait fournir des milliers d'Ampères de courant. S'il y a un court-circuit sur la longueur des câbles connectant la batterie à l'onduleur, des milliers d'Ampères de courant seraient produits. Le câble serait en surchauffe, l'isolation fondrait, et finirait par briser. Cette interruption de courant fort va produire une haute température qui peut être dangereuse, ainsi qu'un arc électrique très puissant accompagné d'une vague de forte pression qui pourrait causer un incendie, endommager les objets environnants et occasioner des blessures. Pour prévenir l'apparition de conditions dangereuses dans des conditions de court-circuit, le fusible utilisé dans le circuit de la batterie devrait limiter le courant (qui devrait être " courant Type Limiter " ), souffler dans un temps très court (qui devrait être rapide) et de même , éteindre l'arc d'une manière sûre. A cet effet, le Fusible UL Classe T ou équivalent devraient être utilisés ( Selon la norme UL 248-15 ). Ce courant de but spécial, fusible à action très rapide va souffler en moins de 8 ms dans des conditions de court-circuit. Capacités appropriées de la classe T fusible ci-dessus ou équivalent devraient être installés dans les 7 " de la batterie Plus ( + ) Terminal ( S'il vous plaît voir le tableau 8,2 pour les fusibles ). Noté Marin batterie fusibles, série MRBF -xxx faite par Cooper Bussmann peut également être utilisé. Ces fusibles conformes à la norme ISO 8820-6 pour les véhicules routiers.



#### MISE EN GARDE!

Il est obligatoire d'utiliser un fusible de la bonne taille (comme décrits au-dessus), afin de réduire la risque d'incendie à cause d'un court-circuit accidentale des fils de batterie. S'il vous plaît noter que les fusibles internes de côté CC sont conçues pour protéger les composants internes de l'onduleur contre les surcharges de côté CC. Ces fusibles vont pas s'exploser s'il y a un court-circuit sur la longueur des câbles connectant la batterie à l'onduleur.

### 8.4.5 Tailles recommandées des câbles de batterie et fusibles

Les tailles des câbles et des fusibles sont présentées dans le tableau 8,2. Le calibrage est fondée sur des considérations de sécurité spécifiées dans UL -458 , NEC - 2014 et ISO - 10133 . S'il vous plaît se référer à " Remarques pour le tableau 8,2 " pour plus de détails.

Tableau 8,2 Dimensionnement des câbles de batterie et fusible de côté de batterie externe Recommandé							
Modèle No.	Courant d'entrée maximal CC continu (voir note 1)	Ampacité minimum de câble selon NEC (voir note 2)	Taille maximale Fusible externe Batterie (Basé sur la colonne 2) (voir note 3)	La taille minimale du câble (voir note 4)			N ° de pièce recommandée trousse d'installation d'onduleur Samlex Amérique (voir note 5)
				3 ft / 0.91M	6 ft / 1.83M	10 ft / 3.05M	
(1)	(2)	(3)	(4)	(5)	(6)	(7)	(8)
PST-3000-12	360A	450A	400A	AWG #4/0	AWG #4/0	2x AWG # 2 / 0	Trousse CC-3500
PST-3000-24	180A	225A	200A	AWG#2	AWG#2	AWG # 1 / 0	Trousse CC-2000



## NOTES POUR LA TABLE 8,2

- 1) La colonne 2 indique le courant d'entrée nominale continue CC tirée de la batterie.
- 2) La colonne 3 indique minimum pour le dimensionnement de l'intensité admissible NEC de conducteurs. NEC Ampacity is not less than 125% of the rated continuous DC input current (Column 2) - Refer to NEC-2014 (National Electrical Code) - Section 215.2(A)(1)(a) for Feeder Circuits.
- 3) Colonne (4) indique la taille du fusible externe dans le circuit de la batterie. Il est obligatoire d'installer ce fusible dans les 7 " de la borne positive de la batterie pour protéger les câbles de batterie contre les courts-circuits. Amp du fusible est basé sur les considérations suivantes:
  - a) pas moins que le maximum du courant continu d'entrée CC (colonne 2)
  - b) Le standard de fusible en Ampère le plus proche a été utilisé - Reportez-vous à NEC – 2014 (Code Electrique National) - Section 240,6 ( A)
  - c) Lorsque la norme de Fusible ne correspond pas à la Ampacité nécessaire ( colonne 2 ) , le Standard du fusible suivant a été utilisé - Reportez-vous à NEC - 2014 (Code Electrique National) - article 240,4 ( B )
  - d) **Type de fusible** : action rapide , limitation de courant , UL Classe T ( norme UL 248-15 ) ou équivalent
- 4) Colonnes 5 à 7 indiquent une dimension du conducteur minimum. Qu'est basée sur les éléments suivants 2 considérations. **Les conducteur plus épais sur les considérations suivantes on été choisi:**
  - a) Selon les lignes directrices de l'ISO 10133 pour 105 °C isolation de câble et câbles à l'air libre. Taille de conducteur est basé sur :
    - (i) NEC Ampacité précisé à la colonne 3,
    - (ii) Le conducteur en cuivre avec température nominale de 105 ° C / 221 F et
    - (iii) La température ambiante de 30 ° C / 86 ° F b)
  - b) Chute de tension à travers la longueur des câbles limités à 2% de 12V / 24V.
    - i) La chute de tension a été calculée en multipliant le courant nominal d'entrée CC (Colonne 2) et la résistance de la longueur totale du conducteur de cuivre **(la longueur totale du conducteur a été prise comme 2 fois la distance de déplacement entre l'unité et la batterie à couvrir 2 longueurs de positif et de conducteurs de câble négatif).**
    - ii) Résistance du câble sont basées sur le Tableau 8,1.
- 5) Samlex America, Inc. donne de 4 modèles de générique / Kits d'installation de convertisseur universel pour couvrir les exigences d'installation d'une large gamme de puissance allant de 600W à 3500W pour 12V inverseurs et de 1200W à 7000W 24V inverseurs. Veuillez noter que le kit d'installation onduleur qui a été recommandée dans la colonne (8) peuvent inclure plus épais Taille de fil / proportionnellement plus grande taille de fusible que celles recommandées dans le tableau 8.2. C'est acceptable.

Fusible dans le circuit de batterie est requis principalement pour la protection contre les courts-circuits dans le câble de batterie s'exécuter. La taille de ce fusible doit être égale ou supérieure à la taille maximale Courant CC en entrée de l'inverseur à la colonne (2). En outre, l'ampérage du fusible utilisé pour protéger un câble de batterie contre court-circuit doit être inférieur au courant admissible du câble de façon à ce que le fusible saute avant l'isolation du câble est endommagé en raison d'une surchauffe en raison d'un courant de défaut supérieur au courant admissible du câble. L Amp de fusibles fournis à cotes les Kits d'installation onduleur sont inférieures à la taille du fil fourni avec le kit.

Les kits sont livrés avec 10ft longueur de câbles à couvrir batterie pour onduleur distance de jusqu'à 10 ft. Si la distance de routage réelle du câble de la batterie de l'onduleur est inférieure à 10ft, veuillez couper la longueur supplémentaire de câbles. Cela entraînera une réduction dans la résistance globale du câble / réduction de chute de tension et, par conséquent, amélioreront l'efficacité de l'onduleur.

#### 8.4.6 Connexion d'Entrée CC

Les bornes d'entrée CC pour la connexion à la batterie (14 et 16 dans la Fig. 6.1c) ont des connexions à écrou et boulon - taille de boulon de 7,81mm ou 5/16po (18 filets par pouce). Utilisez des bornes à type cosse sur les terminaisons de câble pour s'adapter au boulon.

#### 8.4.7 Réduction d'Interférence de FR

Veuillez suivre les recommandations écrites à la Section 3 - «Réduction d'Interférence Electro-magnétique»

### 8.5 CONNEXIONS DE CÔTÉ CA



#### **MISE EN GARDE! Empêcher la Sortie CA de Se Mettre en Parallèle**

1. La sortie CA de l'appareil ne peut pas être synchronisée avec une autre source CA et ainsi, ce n'est pas approprié de la mettre en parallèle. La sortie CA de l'appareil devrait jamais être directement branchée à un tableau électrique qui est aussi alimenté par la puissance d'un service public / générateur. Une connexion pareille pourrait résulter dans un fonctionnement en parallèle de ces sources de puissance diverses et, la puissance CA produite par le service public / générateur serait alimentée à l'appareil causant des dommages à la section de sortie, engendrant un risque d'incendie ou pourrai faire du mal. Si le tableau électrique est alimenté par l'appareil et une puissance provenant des autres sources CA est requise, la puissance CA venant de toutes les sources comme le service public / générateur / l'onduleur devrait être alimentée en premier, à un sélecteur et, la sortie du sélecteur devrait être liée au tableau électrique.
2. Pour empêcher la possibilité que l'onduleur se met en parallèle ou s'endommage sévèrement, n'utilisez pas un câble de raccordement avec un fiche de chaque côté pour brancher la sortie CA de l'onduleur à un réceptacle mural commode dans la maison / RV

### 8.5.1 De neutre à la masse du châssis Bond

Les fentes de position neutre de la NEMA5-20R Le GFCI Récipients Duplex (6, fig 6.1a) et la borne neutre pour hardwiring (13, fig 6.1a) sont intérieurement collée au châssis métallique de l'onduleur.

### 8.5.2 Connexion de Sortie CA à Travers un Dispositif Différentiel à Courant Résiduel (DDR)

Un chemin électrique involontaire d'une source de courant vers une surface (la terre) s'appelle un défaut d'isolation ou courant résiduel. Un défaut d'isolation existe quand il y a une fuite à la terre. Le chemin qui est pris par le courant est assez important, si votre corps fait partie de cet chemin, vous pourriez être blessé, brûlé ou même électrocuté (le corps humain sec a une faible résistance d'un K Ohm). Le Dispositif Différentiel à Courant Résiduel (DDR) vous protège contre des décharges électriques en détectant des fuites et ensuite en coupant la source CA.

L'AC Sortie de ce convertisseur est disponible par le biais d'un NEMA5-20R Le GFCI Récipient Duplex (6, fig 6.1a) et aussi par le biais de hardwiring connexions du terminal situé dans un compartiment (13, fig 6.1a) derrière le récipient GFCI. La rainure Neutre du réceptacle (la rainure rectangulaire plus longue) et la borne neutre " N " du bornier pour la sortie CA du câblage ( 13 , figure 6.1b ) sont liée intérieurement au châssis de l'onduleur.

Une lumière d'indication sur la prise GFCI serait allumée si le DDR fonctionne normalement et s'éteindrait si le DDR est déclenché.

Le DDR est fourni avec les boutons suivants:

- **Bouton de Réinitialisation:** Au cas où le DDR est déclenché, on peut réinitialiser le disjoncteur en appuyant sur le «Bouton de Réinitialisation».

**REMARQUE :** Pour le bouton de réinitialisation pour fonctionner, l'onduleur doit être sur l'État et devraient être sortie de l'alimentation secteur du côté interne de conduite du disjoncteur de fuite à la terre (pas de panne / condition d'arrêt).

- **Bouton de Test:** Ce bouton est utilisé pour vérifier que l'onduleur fonctionne normalement. Testez l'onduleur périodiquement pour assurer un bon fonctionnement.

Le DDR va déclencher dans les conditions suivantes:

- Lorsq'une fuite (Leakage of 5 to 6 mA)
- Si le Neutre est lié à la connexion de terre sur le côté de charge du DDR.



#### ATTENTION!

1. Chacune des sorties de NEMA5-20R est fait pour 16A et 20A continue intermittente. Ne pas tirer plus de cette charge de chaque sortie . Pour utiliser la pleine capacité de puissance nominale de 25A de l'onduleur , utiliser des connexions de sortie CA au câblage ( 13 , figure 6.1b ), comme décrit à la section 8.5.2 ci-dessous.

2. Ne dirigez pas la sortie du réceptacle DDR à un tableau électrique lorsque le Neutre est lié à la terre. Ça va déclencher le DDR. S'il y a un besoin d'alimenter la sortie CA à un tableau électrique, utilisez des connexions à câblage (veuillez voir les informations présentées à la section 8.5.2 ci-dessous).
3. Si une rallonge est utilisée pour la sortie GFCl, veuillez vous assurer que le cordon est mise à la masse à 2 pôles type avec connecteurs NEMA5-205-15P / NEMA P plug.

### 8.5.3 Connexions de Sortie CA pour le Câblage

Des connexions séparées sont disponibles pour connecter la sortie CA de l'onduleur à un tableau électrique CA. Veuillez référer à la Fig. 6.1, le Compartiment (11, Fig 6.1b) contient les bornes de sortie CA. Il est recouvert par une plaque (8, Fig 6.1a) à l'aide de 4 vis. Le câblage CA entre par la souche de métal (7, Fig 6.1a) . Une fois que les connexions ont été effectués, serrer le collier. Connexions de sortie AC sont comme suit :

#### Bornier ( 13 , figure 6.1b ) avec les bornes ligne "L" et "N" Neutre

Veuillez noter que la borne Ligne «L» du serre-fils CA (13, Fig 6.1b) et la borne ligne (sur le côté de ligne du DDR) (6, Fig 6.1a) sont connectées intérieurement au PCB (circuit imprimé). Semblablement, la borne Neutre «N» du serre-fils CA (13, Fig 6.1b) et la borne Neutre (sur le côté de ligne du DDR) (6, Fig 6.1a) sont connectés intérieurement au PCB.

- Diamètre du Trou: 4.15mm / 0,16po
- Vis à Pression: #6 (UNF«filet fin», 40 filets par Po) ou M3,5 (Grand Pas de Vis de 0,6mm)

#### Borne de Terre CA (12, Fig 6.1b)

- Goujon: #6 (UNC «gros filet», 32 filets par po)

#### Liason du Neutre au Châssis de Terre

- Le Neutre «N» est lié au châssis de métal du l'onduleur à travers un boucle de fil connectant la borne «N» sur le côté de Ligne du DDR au châssis de l'onduleur.



#### MISE EN GARDE!

**RISQUE DE DÉCHARGE ÉLECTRIQUE** lorsque cette unité est installée dans des véhicules, et une connexion de câblage est utilisée pour envoyer la sortie CA de l'onduleur au tableau électrique, veuillez assurer que le(s) dispositif(s) différentiel(s) à courant résiduel [DDR] est/sont inclus(s) dans le système d'installation électrique du véhicule pour protéger tous les circuits de dérivation.

Les GFCl dans le tableau 8,3 ont été testés pour fonctionner de manière satisfaisante et sont acceptables . Autres types risquent de ne pas fonctionner correctement lorsqu'il est connecté à cet onduleur :

Tableau 8,3 information GFCl		
Fabricant du DDR	No. de Modèle	Description
Pass & Seymour	Série 2095	NEMA5-20 Duplex de 20A
Leviton	Série N7899	NEMA5-20 Duplex de 20A
Zhejiang Trimone	Série TGM20	NEMA5-20 Duplex de 20A

### 8.5.4 Câblage de sortie CA- Dimensionnement de câblage et de briseur

Tailles de ligne et les conducteurs neutre et disjoncteur sont présentés dans le Tableau 8,4 . Le calibrage est fondée sur des considérations de sécurité spécifiées dans UL -458 et NEC - 2014 . S'il vous plaît se référer à " Remarques pour le tableau 8,4 " pour plus de détails .

**Exemple de types de câbles CA :** ( a ) 12/3 , Loomex / Romex ( NMD- 90 ) - gainés non métalliques ; Sec : 90 ° C . Ceci est un conducteur-3 ( ligne à isolation , neutre a terre et nu ) , AWG # 12 câble utilisé pour le câblage résidentiel ( b ) les types de cordon CA: SE , SEOO , ST , STO , SJ , SJEOO , SJT ou TJSO .

Pour une connexion ferme lors de l'utilisation ensemble type de bornes à vis pour la connexion du fil torsadé , utiliser " les cordes de borne " pour la terminaison de la ligne nue et extrémités neutres de conducteurs et " type bouclé de borne » pour la résiliation de l'extrémité du conducteur de terre. Pour plus de commodité , les terminaux suivants ont été fournis :

**Pour la ligne et des conducteurs neutres :** 2 pièces de cordon borne pour la taille du conducteur AWG # 12

**Pour conducteur Neutre :** 1 morceau de boucle de borne pour # 6 et de la taille du conducteur AWG # 12



#### ATTENTION!

- (a) Utiliser l'outil de sertissage appropriée pour sertir les bornes sur les extrémités nues des conducteurs .
- (b) Assurez-vous que le câble d'alimentation est suffisamment serré par la décharge de traction métallique (7, Fig 6.1a )

**Tableau 8,4 Dimensionnement Recommandé des câblage de sortie CA et le disjoncteur**

Modèle No.	Courant de sortie en CA continu maximum	Ampacité minimum de ligne de sortie CA et conducteurs neutre conforme NEC ( 125 % fois la colonne 2 )	La taille maximale de disjoncteur de sortie CA externe (Basé sur la colonne 3 )	La taille minimale de la ligne et des conducteurs neutres sur la base Ampacité à la colonne 3 (Ampacité basée sur la température du conducteur de 90 ° C )
(1)	(2)	(3)	(4)	(5)
PST-3000-12 & 24	25A	31.25	30A	AWG#12

#### NOTES POUR LA TABLE 8,4

- 1) La colonne 2 indique le courant de sortie en CA continu
- 2) La colonne 3 indique NEC Ampacité sur la base sur la taille du câble de conducteur (Colonne 5) est déterminée. NEC Ampacité est pas moins de 125% de la production de CA continue courant nominal (colonne 2) - Reportez-vous à NEC-2014 (code électrique National) - Section 215,2 (A) (1) (a) pour les circuits d'alimentation.

- 3) La colonne 5 indique la taille du conducteur pour la ligne et les conducteurs neutre et fondée sur les directrices dans NEC 2014 Tableau 310,5 (B) (16) pour des conducteurs en cours d'exécution dans le conduit / chemin de roulement.
- (a) NEC Ampacité précisé à la colonne 3, mais limitée à la taille de disjoncteur de 30A (colonne 4).
- (b) le conducteur en cuivre avec cote de température d'au moins 90 ° C / 194 ° F
- (c) de température ambiante de 30 ° C / 86 ° F
- 4) Colonne (4) indique la taille maximal des disjoncteurs externe CA (30A) basé sur l'ampacité NEC de 30A pour AWG # 12 conducteur isolé de cuivre (colonne 5) évalué à 90 ° C / 194 ° F à 30 ° C / 86 ° F ambiante - Reportez-vous à NEC-2014 Table 310,15 (B) (16) pour des conducteurs de course dans un conduit / chemin de roulement.

## 8.6 LIASON DE TERRE AU SOL OU À UN AUTRE CONDUCTEUR DE TERRE

Pour la sécurité, mettez le châssis de l'onduleur à terre (sol) ou autre conducteur de terre désigné (par exemple, pour un VR qui est mobile, le cadre de métal sert normalement aussi comme conducteur de terre négatif CC). Un châssis de mise à la terre ( 19 , figure 6.1c ) a été prévu pour la terre du châssis métallique de l'onduleur à la terre appropiée .

Pour l'usage d'un onduleur dans un bâtiment, connectez un fil en cuivre à brins isolés d'une taille AWG #8 ou 10mm<sup>2</sup> de la mise à terre jusqu'à la connexion de terre [sol] (la connexion qui liée à une barre de terre, à une pipe d'eau, ou autre connexion qui est bien liée à la terre [sol]). Les connexions doivent être bien serrées contre le métal nu. Utilisez des rondelles dentellées pour pénétrer la peinture et la corrosion.

Lors de l'utilisation de l'onduleur dans un RV mobile, connecter un 10 mm<sup>2</sup> ou AWG # 8 fil de cuivre isolé brin de la terre du châssis ci-dessus pour la barre de bus principal à la terre du RV ( lié au châssis du véhicule ) . Les connexions doivent être bien serrées contre le métal nu. Utilisez des rondelles dentellées pour pénétrer la peinture et la corrosion.

## 8.7 COMMANDE À DISTANCE RELIÉ PAR FILS (FACULTATIVE) – MODÈLE RC-300



### ATTENTION!

Pour la télécommande optionnelle RC- 300 , l'onduleur doit d'abord être activée à l'aide des commandes ON/ OFF suivants :

- a) **Lorsque que vous n'utilisez pas des contrôle externe du fils 1 ou fils 2 ON/OFF:**  
En appuyant sur l'extrémité supérieure ( marquée " - " ) de l' interrupteur à 3 positions (1, Fig 6.1a ) à la position marqué «ON»
- b) **Lors de l'utilisation des contrôle externe du fils 1 ou fils 2 ON/OFF:** En poussant PREMIER extrémité inférieure ( marquée " = " ) de l'interrupteur du positions 3 (1, Fig 6.1a ) à la position marquée " EXT . interrupteur " puis passer sur l'onduleur par ( i ) la fermeture du contact de l'interrupteur ou relais fils 2 Contrôle ON / OFF ( figure 8.2a ) ou ( ii ) la fermeture du contact de l'interrupteur ou relais Fils 2 Contrôle ON / OFF en utilisant la tension CC ( figure 8.2b ) ou ( iii ) la fermeture du contact de l'interrupteur ou relais fils 1 régulation ON / OFF à l'aide la tension CC de la batterie qui fournit l'onduleur .

Une Commande à Distance Relié par Fils, Modèle RC-300 (avec 25 ft / 5.2 mètres de câble) est disponible pour diriger la commutation des états EN MARCHÉ et ARRÊT et la surveillance. Elle est équipée avec affichage ACL qui affiche la tension de sortie CA, A, Hz, W, VA, et Facteur de Puissance. Elle a aussi des lumières d'indication pareilles aux indications du panneau de devant (2, 3, 4 dans la Fig. 6.1a). La télécommande est reliée au port RJ-50 jack (9, figure 6.1a). Pour en savoir plus, lisez le guide de la Commande à Distance.

## 8.8 ON / OFF contrôle de distance à l'aide fils 2 ou fils 1 externe contrôle ON / OFF



### ATTENTION!

Pour le fonctionnement de cette fonction, le commutateur positions 3 sur la face en avant marquée "ON / OFF / EXT". commutateur (1, Fig 6.1a) doit d'abord être poussé à l'extrémité inférieure (marquée "=") pour le basculer au fond "EXT". commutateur ".

L'appareil peut être activé / désactivé à partir d'un emplacement distant en utilisant, filaires ON / OFF dispositifs de commande extérieurs comme le montre la figure 8.2 (a), (b) et (c). Des détails sont donnés ci-dessous:

- **2-Fils ON / OFF contrôle de distance à l'aide d'un commutateur/Contact de relais, la figure 8.2 (a) :** Dans cet arrangement, source de tension externe est pas nécessaire. L'onduleur commute ON lorsque le contact de relais / interrupteur est fermé et les terminaux 1 et 2 du bornier (10, figure 6.1a) sont court-circuités. The inverter will switch OFF when the relay contact / switch is opened and short is removed across terminals 1 and 2 of the Terminal Block (10, Fig 6.1a)
- **Le convertisseur est arrêté lorsque le contact de relais / interrupteur est ouvert et court est retiré entre les bornes 1 et 2 du bornier (10, figure 6.1a) 2 -fils ON / OFF contrôle utilisant une tension CC commuté (10-33VDC), figure 8.2 (b) :**



### ATTENTION!

1. S'il vous plaît assurer la polarité de la connexion de câblage. Positive (+) de la source du CC externe source doit être connecté à la borne 3 du bornier (10, Fig 6.1a) et négatif (-) à la borne 4. Dans le cas où la polarité est inversée, le contrôle ON / OFF ne fonctionnera pas. **L'entrée à ces bornes est protégé contre les inversions de polarité**
2. Utilisez fusible 1A comme indiqué le plus près de la source de courant continu que possible



### INFO

Le signal de commande externe 10-30VCC sur les bornes 3 et 4 du bornier (10, figure 6.1a) alimente un opto-isolateur interne. Par conséquent, le terrain négatif de la source de 10-30VCC externe peut être isolée de la masse négative de l'entrée de la batterie de l'onduleur.

L'onduleur commute ON lorsque le contact de relais / interrupteur externe est fermé [ tension continue externe ( 10-33VCC ) est alimenté aux bornes 3 et 4 du bornier ( 10 , figure 6.1a ) ] . Le convertisseur est arrêté lorsque le contact de relais / interrupteur externe est ouvert [ tension de CC externe ( 10-33VCC ) est retiré de bornes 3 et 4 du bornier ( 10 , figure 6.1a ) ] .

- 1-Fils ON / OFF contrôle utilisant une tension CC est en marche à partir de la batterie alimentant l'onduleur , la figure 8.2 ( c ) :



**ATTENTION!**

1. S'il vous plaît assurer la polarité de la connexion de câblage . Positive ( + ) de la tension de la batterie doit être connecté a la borne 3. Au cas où la polarité est inversée, le contrôle ON / OFF ne fonctionne pas. L'entrée à cette borne est protégé contre les inversions de polarité
2. Utilisez fusible 1A comme indiqué au plus près du point d' entrée de la batterie que possible

L'onduleur commute ON lorsque le contact de relais / interrupteur externe est fermé [ tension de la batterie 12V / 24V alimentant le variateur est alimenté à la borne 3 du bornier ( 10 , figure 6.1a ) ] . Le convertisseur est arrêté lorsque le contact de relais / interrupteur externe est ouvert [ tension de la batterie 12V / 24V alimentant le convertisseur tension continue est retiré de la borne 3 du bornier ( 10 , figure 6.1a ) ] . **Dans un véhicule / RV , la tension de commande peut être alimenté directement à partir du commutateur d'allumage. Cela va passer sur l'onduleur lorsque le contact est mis et éteint l'onduleur lorsque le contact est coupé .**

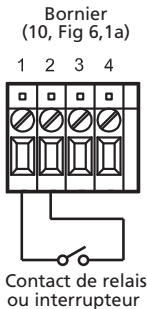

**Fig 8,2 ( a )** - 2 –fils utilisant contrôle ON / OFF commutateur / contact de relais

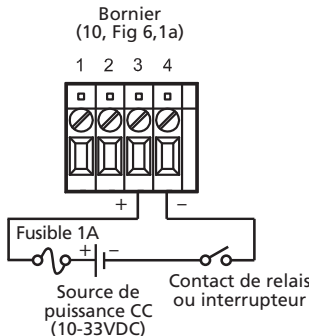

**Figure 8,2 ( b )** - 2-fils contrôle ON / OFF en utilisant commuté tension CC

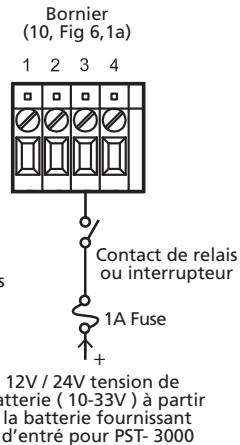

**Figure 8,2 ( c )** - 1-fils ON / de contrôle utilisant commuté tension CC de la batterie fournissant l'onduleur

**NOTE:** taille de fils: AWG #22

*Figure 8.2 : ON / OFF contrôle de distance à l'aide externe à 2 fils ou 1-fil de contrôle*









# Contact Information

## Toll Free Numbers

Ph: 1 800 561 5885

Fax: 1 888 814 5210

## Local Numbers

Ph: 604 525 3836

Fax: 604 525 5221

## Website

[www.samlexamerica.com](http://www.samlexamerica.com)

## USA Shipping Warehouses

Kent, WA

Plymouth, MI

## Canadian Shipping Warehouse

Delta, BC

Email purchase orders to

[orders@samlexamerica.com](mailto:orders@samlexamerica.com)



**samlex**america®